

# GLIDER PILOT



Peter Champion

# Ex Libris



From the Gliding Library of  
**Wally Kahn**

# GLIDER PILOT

---

# GLIDER PILOT

---

Peter Champion

MODEL AND ALLIED PUBLICATIONS LIMITED  
13-35 Bridge Street, Hemel Hempstead, Hertfordshire,  
England

Model and Allied Publications Limited  
Book Division,  
Station Road, Kings Langley,  
Hertfordshire, England

First Published 1974

© Peter Champion 1974

Jacket Painting and all line illustrations  
and photographs by Peter Champion.  
© Champion Aviation Marine. All Rights Reserved.

ISBN 0 85242 364 0

Monophoto set in 11/12 Garamond by  
Keypools Ltd, Golborne, Lancashire

Printed by Clarke, Doble & Brendon Ltd., Plymouth

---

# Preface

---

This story portrays the experiences of one glider pilot who is indebted to the Southdown Gliding Club for the five and a half years they have put up with him.

It is in no way an instructional book and you are warned that should you take up the sport of gliding (and I hope you will), the opinions and flying procedures discussed in this book in no way constitute instruction or advice unless approved by your own gliding instructor.

For those of you seeking an instructional book I heartily recommend: *Gliding*, by Derek Piggott, published by A. & C. Black.

Peter Champion, 1973

---

# Contents

---

The Cruel Sky

*Page 8*

Introduction

*Page 10*

*Chapter One*

I was free at 2250 feet!

*Page 11*

*Chapter Two*

You'll never do anything else

*Page 19*

*Chapter Three*

I began to feel sick and dizzy

*Page 28*

*Chapter Four*

Is your number up?

*Page 37*

*Chapter Five*

'You have control,' said George

*Page 45*

CONTENTS

*Chapter Six*  
Quite happy to fly  
*Page 52*

*Chapter Seven*  
'It's all yours!'  
*Page 60*

*Chapter Eight*  
A three-minute period in one's life  
*Page 66*

*Chapter Nine*  
Flying is full of characters  
*Page 71*

*Chapter Ten*  
Conversation with my headless companion  
*Page 78*

*Chapter Eleven*  
A bad example  
*Page 86*

*Chapter Twelve*  
Thermals popping up  
*Page 96*

*Chapter Thirteen*  
A day in a lifetime  
*Page 103*

*Chapter Fourteen*  
The pilot who is never wrong  
*Page 109*

Postscript  
*Page 113*



---

THE CRUEL SKY

---

*On broomstick mounted rides the witch,  
And pulls into the climb.  
I wish I could control the bitch,  
And fly it right this time.*

*I let the towing cable go,  
And throttle back the speed.  
I'm dropping through the sink I know:  
It's bloody lift I need.*

*For years and years and years I've trained,  
To fly the stupid cow,  
And every brittle bone I've maimed,  
And still I don't know how.*

THE CRUEL SKY

*Oh why are all my thermals rough?  
As up and up I climb.  
I really think I've had enough;  
My stomach's far behind.*

*I see the world go round and round  
As circles I do fly;  
Oh dear! Oh dear! I'm coming down,  
And falling out the sky.*

*I'm landing now behind the fence;  
Oh why! Oh why! I cry?  
'You've too much brake – too little sense,'  
Shouts out the C.F.I.*

*The altimeter up, I'll wind,  
One day upon the ground.  
And then I'll leave them all behind  
In all the lift I've found!*

---

## Introduction

---

The fear instilled in the author by his early flying experiences possibly entitles the reader to some brief explanation of how this 'custard pie' state of mind came about.

In the early 1960's, for reasons which are irrelevant, I suffered what is popularly known as a nervous breakdown, followed by extreme agoraphobia. This fear of open spaces was so acute that a walk away from the house of a few hundred yards became an impossibility and only after eventually flushing all the doctor's pills down the 'loo' and making a big effort over a number of years did the condition subside.

Joining a gliding club was to be the final cure as I reasoned that there could be no more open space than twirling gaily around in the sky. Flying somewhat aggravated the old problem of agoraphobia but after some more years of persistence it finally subsided.

It only remains to state here that some of the incidents mentioned in this book concerning the exploits of other fliers may lead the reader to assume that the standard of instruction might be somewhat questionable. It is only right that an emphasis should be laid here and now that the quality of instruction at gliding clubs in the United Kingdom is second to none and when it is considered that most of the instructors are unpaid volunteers I feel that this displays an outstanding record.

Peter Champion, 1973

---

# I was free at 2250 feet!

---

The mist was clearing from the airfield as the Tiger Moth taxied towards the parked gliders. In spite of weather forecasts declaring low overcast cloud and rain, the sky was now clear and the wind light.

Although the late October morning thrust a penetrating cold into my bones, I was hot around the neck and tense as I sat in the glider cockpit. The Tiger Moth passed in front of me and with a roar of its engine turned, presenting a shuddering tailplane and a sudden slipstream that flattened the soft grass and sent slivers of cold air rushing past my face.

The 'Moth' bore the name 'Deacon', and was resplendent in a sunburst of black and yellow stripes on the top wing. A long white nylon towing-line hung from a stanchion beneath the tail and slithered through the grass like some elongated worm. The Tiger Moth's engine spluttered, coughed and suddenly died: the propeller coming to a halt in a series of jerky movements.

One wing of my glider was leaning on the ground. My detachable cockpit canopy was beside me.

The Tiger Moth pilot jumped nimbly from his mount, and walked slowly towards me and the other chattering glider pilots who surrounded my machine. He stopped halfway, yawned and lit a cigarette before joining our little band, whereupon he selected our Duty Flying Instructor as though possessed of a sixth sense and jabbed a gloved index finger in my direction.

'First solo aero-tow?'

The duty instructor nodded, and they both smiled at one another, and I noticed the other glider pilots were smiling too, some of them awaiting their first tow into the skies by Tiger Moth. I imagined their smiles would fade somewhat when their turn came.

The Tiger Moth pilot approached me and leaned lazily on the nose of my red and white glider.

'This can be bloody dangerous,' he said, casually, echoing my own sentiments on the subject at that moment, 'and I want you to remember to keep low over the airfield on take off. Your glider will lift off before my tug plane, and if you climb too high you will pull my tail up and I shall plough a long furrow in the ground.'

My mouth was dry: my tongue flopped around inside it like an old leather shoe.

I nodded.

He sniffed and drew hard on his cigarette.

'I shall tow you to about 2,000 feet,' he added, 'and when I waggle my wings you will pull the cable release. If you fail to do so I shall release you, cable and all. Then, I shall break to the right and you will break to the left; got it?'

'Got it,' I croaked.

'Also, don't get too high or too low into my slipstream.'

'Right,' I confirmed.

He smiled again and patted the red nose of the glider.

'Not exactly Concorde, is she,' he quipped.

'Not exactly,' I agreed.

'By the way,' he added, more in afterthought, 'if you are unable to release the towline for any reason, fly out to the left of me and waggle your wings. I'll release you and you'll have to make your way back to the field and do a steep approach, towline and all.'

I swallowed, but there was a drought of saliva.

The duty instructor was standing at my side grinning from ear to ear; in fact, everyone around me was grinning. I wondered whether or not they thought it instilled confidence and assurance or whether it was, in fact, a mask for their own particular feelings.

I turned to the tug pilot.

'Anything else?'

He glanced skywards and then to the south.

'Just watch out for jets taking off from Gatwick. We are pretty near their airspace and sometimes they overlap.'

'Mm . . . m,' was all I could muster in reply.

'Any problems?' grinned the duty instructor.

The man's a mind-reader, I thought. My head was just about bursting with problems, and like a computer was trying to programme the real hazards from the imaginary.

I looked up into the smiling face.

'Problems?' I echoed, 'no, of course not.' I lied with the deftness of a confidence trickster, and as I uttered the words opposing thoughts flashed across my mind.

What of those trees at the far end of the airfield? They appeared terribly high. Supposing the towline broke just before we reached them; would I be able to get the glider down in one piece? . . . the glider down in one piece? . . . to hell with the glider! . . . what I meant was, would I be able to finish up in one piece myself?

By this time the duty instructor had picked up my canopy from the grass and held it in front of me.

'Cockpit checks complete?' he asked.

'Canopy and brakes to check,' I confirmed, and he slotted the bulbous perspex hood over my head and I let go the securing trigger with a thud worthy of a Kamikazi pilot.

I pushed upwards on the canopy to check that it was locked, and my shaking fingers manipulated the airbrake lever clanking the brakes open and closed in the wings. I locked them with a final push on the lever and let my eyes flit over the instruments, the trim setting: hunching my shoulders to ensure the straps were tight, and looked up with what must have appeared an ashen smile.

Another glider pilot had raised the leaning wing from the ground balancing the glider on its single belly wheel and nose skid.

The tug pilot had climbed back into his Tiger Moth, and a glider pilot was swinging the prop. The engine burst into life and the glider rocked slightly in the renewed slipstream.

Little legs were running this way and that as signallers and other glider pilots took up positions.

A face appeared outside the cockpit and I opened the small clear-vision panel.

He had the other end of the towline in his hand from which dangled the two linked towing and safety rings.

'Ready?' he grinned. I wished they'd all stopped grinning.

I nodded.

'Airbrakes closed and locked?' he checked.

'Closed and locked,' I panted.

‘Cable on.’

‘Open,’ I shouted pulling the yellow knob to the left of the instrument panel and freeing the towhook to engage the linked rings.

‘Closed!’ he shouted, slotting the rings into position.

‘Closed,’ I replied, and let the yellow knob spring back into its mount.

He stood up, tugged the towline to ensure it was secure and walked away.

My mouth now seemed drier than ever, and as the final pockets of morning mist evaporated from the far corner of the field my eyes searched the sky for any possible hazard.

‘All clear above and behind?’ I called out to the signaller standing in front and to one side of the glider.

His head searched the sky afresh and corkscrewed around in all directions.

‘All clear,’ he acknowledged.

‘Take up slack,’ I instructed, raising one finger of my left hand as a visual confirmation, while gripping the control stick with my right hand, and pressing my feet firmly on the rudder pedals.

The signaller waved his bat low under his waist while another signaller in front of and to one side of the tug relayed the signal to the pilot of the Tiger Moth. The engine of the tug revved up: the slipstream flattened the grass now and the wings of the glider were trying to dance in the fast airflow as the wing man held on to the left wing tip.

The tug trundled forward and the white nylon towline straightened itself, tugging at my towhook and rocking the nose of the glider up and down.

My heart was thumping its way out of my chest by now as I gave the final order for take-off.

‘All out!’ I yelled, raising a further finger of the left hand to the signaller, which gesture, fortunately for glider pilots, is never mistaken for the show-jumping style of Harvey Smith!

The order was conveyed to the tug pilot and my wing man was ready to run with the glider, balancing the wing until finally our speed outstripped him.

Over the past five years I had flown 384 glider flights and 189 of them solo, but this morning I felt just like I did that other morning 189 flights before, when I had given the order for take-off on my first-ever solo flight. The same emotions, problems, fears and

excitement.

The Tiger Moth trundled forward, slowly at first and then with a sudden increased acceleration that left my wing man far behind. The glider was cutting its way quickly over the turf and I had to correct quickly with the rudder pedals to stay behind the tug's tail-plane. The airflow over the wings and control surfaces was biting, and in a couple of light bumps I was airborne. The tug, however, was still stuck fast to the ground, and I eased forward on the control stick flying at only a foot above the flashing green shades of grass, and he too bounced and became airborne, tug and glider eating up the yards of field and allowing the pale-purple shadows of those high trees to get larger and larger.

I bit hell out of my lower lip, such was my concentration, but the Tiger Moth lifted and I eased back on the stick, the pair of us rising quickly now as those menacing trees of a few moments before passed slowly beneath us. Fields, roads and a railway line slid gracefully below as the tug and glider bounced through the turbulent air, rising one second and dropping the next. I concentrated like a cat watching a bird, trying to anticipate the next rise or fall of my tug 'plane, and trying desperately it seemed at times not to swing to one side out of station.

'Relax . . . damn it, man . . . relax,' I told myself aloud, and eased my vice-like grip on the stick as I became aware of the sweat in my palms. I slid my head back onto the head rest at the back of the canopy and began to breathe more evenly.

The tug turned slowly right towards the north, and I now found it easier to keep station behind and slightly above him. The pattern of chequered fields gave way to a complete area of houses as we approached Redhill, and I could not help but feel a little strange, as this seemed the most unlikely place for a glider to find itself. But my thoughts were crossed with others as I watched the controls of the Tiger Moth twitching this way and that. The tailplane seemed forever vibrating, and the rudder moving slightly from one side to the other. I wondered vaguely how those 'planes of struts and strings in the First World War had ever managed to shoot each other down in this world of turbulent air and dancing aircraft.

We seemed to be flying right above the centre of Redhill now, and for some silly reason I wondered where Woolworth's was situated.

I glanced at my altimeter.



One-thousand-five-hundred feet it read, as the large white needle crept slowly around the dial.

My concentration moved from the tug to a likely-looking collection of small cumulus clouds cutting across my bows about a mile away. They were white and fluffy with pale-purple troughs and pale-pink crests, and looked as though they might cap sufficient up-currents to sustain a glider for a while. My thoughts were interrupted as the tug suddenly turned right again towards the east and I swung badly out of position to his left, kicking a large bootful of right rudder and aileron and swinging back into position above and behind him. I checked the speedometer on my panel, and it read a frightening 70 knots, or 84 miles per hour. The altimeter told me that we were coming up to 1,900 feet, as the tug turned again and we flew south still climbing when I hurriedly tried to make out the shape of Redhill aerodrome.

'God, it should be there,' I said aloud, staring down at the paint-palette colours of brick, green and grey from the fields below, and there it was: I was looking at it all the time.

The tug rocked his wings laterally, and I eased back slightly on the stick, pulled the yellow knob with my left hand, and watched fascinated as the white nylon line catapulted away in front of me and the tug turned sharply to the right and dived.

I pressed the rudder bar with my left foot and eased the stick simultaneously to the left, pulling back on it as I did so, converting my speed into height. As the airspeed came back to just above 40 knots I levelled off and re-trimmed.

I was free, at 2,250 feet!

I opened one of the clear-vision panels and breathed in the cold air as I flew north away from the airfield and towards the promising clouds that had cut across my bows some minutes before. But on reaching them they were almost down to my altitude and of little use.

I looked around and started a lazy left-hand turn watching the outline of London, Dorking and Guildford, and then south and the silver sliver of Gatwick lay across the green terrain like the mercury in a thermometer, where what looked like a tiny black ant clawed its way steeply into the sky leaving a long finger of black exhaust in its wake.

A variometer on my instrument panel informed me that I was in rising air of about four feet per second, so I tightened the turn a

## I WAS FREE AT 2250 FEET!

little and it took me from 2,000 feet back to 2,250 before the lift petered out. I relaxed once more attracted by the line of silver railway running straight and true from Redhill deep into Kent. My eyes flitted this way and that attracted by the sudden appearance of new white motorways and long fingers of yellow from those still under construction.

I looked down at the white buildings of Fuller's Earth Works surrounded by red brick dust, deep-blue reservoirs to the north and white puffs of smoke from its large chimney. I made for the smoke hoping that the warm rising air might take me up yet once again, but apart from slight turbulence the variometer was still and the altimeter slowly unwinding as I lost altitude.

I was now down to 1,400 feet and turned south, my eyes straining through the sunlight reflected from the perspex canopy of my glider as I picked out the airfield once more. It was some way off now, and between it and me a countless number of pale-green fields roughly chequered with dark-green hedgerows and the darker green of small woods.

The colours now varied with the intervention of wispy cloud and changed in tone and depth.

These sights and countless more were experiences upon which I could feed forever with the gluttony of a child let loose in an ice-cream factory. But as gliders have an annoying habit of coming down unless the air in which they are flying is going up, I decided to fly back to the airfield.

Down the new motorway to the east of the airfield and slightly across it was my cross-wind leg before turning into wind and starting my landing approach onto the airfield.

Having completed the cross-wind leg, I looked out to each side and above me for any other approaching aircraft.

'All alone,' I said aloud. 'Good.'

I looked down at the airfield, and when in what I considered a nice position and well lined-up I looked out once more in a hasty final check for other aircraft. Seeing none, made a clean cut final turn at about 500 feet.

The run in was nice and long with plenty of time to increase my rate of descent with the airbrakes, having increased and re-trimmed my approach speed to 50 knots.

The field floated up, gracefully, slowly and definitely, and as I passed the tall trees on the perimeter I began to ease back on the stick

## GLIDER PILOT

levelling off the glider and floating over the grass about six inches from it. The other parked gliders nearby flashed past in a sudden punctuation of reds and blues. My mainwheel trundled onto the ground, the glider decelerating quickly and stopping about a hundred feet from where I had taken off.

The right wing tip flopped lazily to the ground and I switched off the instruments and bent the lever round to release my straps.

The other glider pilots were running towards me, together with the duty instructor, who I was thankful, was still grinning, so it couldn't have looked too bad.

I released the canopy lock and lifted the whole unit onto the grass, as I sucked in more cold air and felt little beads of perspiration run down my temples. A young glider pilot was the first to reach me and he was due to be the next pilot to make his first aero-tow. He was not smiling.

'Blimey, Pete, what's it like?' he asked, falteringly.

'Piece of cake,' I said, and it was my turn to grin.

---

# You'll never do anything else

---

I found the South Downs between Lewes and Eastbourne easily enough, and located the large field used by the gliding club which ran along the crest of the hills from Firl Beacon (714 feet above sea level) to Bo-Peep Hill. The field then ran south for some half a mile forming a Greek letter 'D' in shape, with the broad base from the Beacon to Bo-Peep Hill. The range of downs is some 400 feet above the valley looking north-east, and the inland Lewes-to-Eastbourne road is plainly visible.

The field itself was rough and pitted, covered with a herd of cattle and large flocks of sheep. It did not seem possible that this could be a flying field or even one for emergency landings, but there was the little group of gliders to the south of the field.

This, my first visit, had been suggested by a gliding phenomenon, 'Pop' Orford by name. 'Pop', seventy years of age when he started full-sized gliding, had soloed at the age of seventy-one and since completed over 360 solo flights. A keen model aircraft enthusiast for years, his first interest in 'flying machines' had started in the trenches during the First World War, from where he had sent drawings to the *Aeroplane* magazine in 1916, and he was, and still is, a very competent artist in oils.

I made my way slowly to the bottom of the field keeping close to the perimeter fence and out of the way of any gliders taking off or landing. I at least knew this much.

On my way down the field I saw a signal light flashing, and as I turned round I noticed the large winch on the crest of the hill revving

## GLIDER PILOT

its engine and heard the 3,000-foot wire cable slither through the grass some way off. Quicker flashes from the light at the glider end of the field followed, and the engine in the winch became more noisy. I then noticed a large red and white glider moving slowly up the field along the ground. It suddenly floated into the air keeping fairly flat for a time before the nose seemed to point skywards at about forty-five degrees, leaving the machine clawing its way terribly slowly into the sky, the sunlight glinting on the cable. I stood staring, transfixed.

The frightening thing went up in a huge arc levelling off over the crest of the hill and above the winch, dipping its nose. The cable suddenly slackened, and a small yellow parachute on the end of the cable allowed the wire to float slowly to earth. The nose of the glider rose and, almost unbelievably, the red and white monster began to float slowly along the hills to the east.

I watched its progress, as a farm tractor with the cable hitched to its rear came haring noisily back to the glider end of the field, its tiny driver bent forward over the steering wheel.

Again I looked at the glider, and was aghast to see its open cockpit and within two small heads side by side, peering over the side. It turned and made its way back along the hill, and then turned again, coming down the field over my head, leaving me in its cold shadow for the fraction of a second. There was a slight whispering noise from its movement through the air, and then it turned again at the bottom of the field. It made yet another final turn before its nose went down and it dived towards the ground. Little oblongs suddenly protruded from both wings and its descent became steeper before the nose gradually rose again putting the machine into a level flight path only inches above the ground. It then floated some two hundred feet before its single main belly wheel touched the grass and the beast came to rest. It stayed level for a few seconds and then one wing tip dropped slowly onto the grass.

It all looked highly dangerous and frightening to me. In addition, the whole flight seemed to have been over in a few minutes. So what was the fascination of this sport?

I reached the end of the field, where about six gliders were parked with one wing tip on the grass held down by a number of old motor car tyres. People were walking, talking and pushing the large glider I had seen flying, back to the launch point. It was impossible to determine who were club members and who were merely Sunday

afternoon strollers.

There was no sign of 'Pop', and I strolled around inspecting the gliders being fascinated by a 'Heath Robinson' creation with an orange fuselage and white wings and tailplane. It was a small machine, a single narrow cockpit entirely open with only a small windscreen on the front of the cockpit, which I felt sure must be more for decoration than for protection from the elements. The white wings met at the top of a tapering flared-up fuselage and seemed to be held there by two small steel wire rods. The inner section of the wings sported twin struts running to the base of the fuselage sides and were themselves stressed with rigging wires.

The whole contraption appeared to be made of wood and covered with fabric (doped reasonably taught), but the wing ribs seemed to be trying to push their way through the wings, resembling an old man's chest.

'That,' said a sudden voice at my side, 'is the "Tutor", an early solo machine.'

I caught a glimpse of a smiling face, and the man had moved on. Early solo machine indeed, I thought. It looked earlier than the Wright Brothers 'Flyer', and about twice as dangerous. I inspected the cockpit, from the centre of which protruded a long broom handle which was the control stick, a lever on the left-hand side and a yellow wooden knob hanging from a piece of cable in front of that. There were two dials on the instrument panel plus a thing that looked like twin thermometers and a bubble balance. . . . The seat straps were faded and worn.

The fact that a man should trust his life in such a creation was completely beyond me, and I was about to leave the field in some haste when I heard 'Pop's' voice behind me.

'How do you like the orange "coffin"?' he enquired.  
'Hello "Pop",' I greeted him, '*that* is about my summing up of the thing.'

He suddenly threw one foot over the side of the cockpit and began to lever himself into its narrow confines.

'You don't fly *this*?' I said to him in horror.  
He clipped on the seat straps and drew the shoulder straps to the common locking panel and clipped them in position.

'It's the best glider on the field,' he claimed.  
'Christ,' I said profanely, 'what are the rest like then?'  
He grinned all over his rugged face and countered: 'Not as good as

the old "Tutor". You really know you are flying when you get up in this.'

I had no doubt whatever that you realised you were flying . . . or had he said 'dying'?

He looked away from me and called to a girl in blue flying overalls: 'Can I have a wing up, please?'

The girl smiled, nodded, removed the tyres from the wing tip, and lifted it. Two young men in flying overalls came forward and manoeuvred the 'Tutor' into wind facing in the direction of the winch. The tractor was haring down the field again bringing the cable from a launch that had gone on unnoticed by me.

I stood back as the little aircraft was surrounded by bodies and 'Pop' began moving the stick and rudder pedals, looking out of the open cockpit and checking that they were functioning.

I saw him tug on the shoulder straps, twiddle something on the instrument panel, and finally pull the lever on the left side of the cockpit. I noticed those two pieces of oblong wood again as they sat upright on the wings.

'Spoilers open and in line,' called 'Pop' to the girl on the wing tip. 'Open and in line,' she confirmed, and then added as he let them shut with a clang: 'Closed and flush with the wing.'

'Pop' nodded and stuck an unlit pipe in his mouth.

I have the greatest respect for 'Pop' Orford, but I must in all honesty confess that this whole scene seemed like a clip from a Disney cartoon entitled *Popeye Goes Flying*.

It was probably all a joke, I thought. At the last minute he would probably jump from the cockpit and there would be hoots of laughter from all and sundry and I should be the one left with the red face.

But there was none of this. One of the men in blue flying overalls took the launch cable from the tractor, and bent down fiddling with the thing by the side of the 'Tutor's' cockpit. 'Pop' pulled the yellow wooden knob with his left hand, the other man having called: 'Open.'

'Open,' replied 'Pop', followed by the other shouting: 'Closed,' and 'Pop' repeating him.

The man with the cable stood up and walked towards me picking up a large round bat and turning to face 'Pop', while the girl still held the wing tip and the glider level on its solitary wheel and nose skid.

'Signals,' shouted the girl at the wing tip.

I looked round to see another young figure run towards a nearby two-wheeled cart and put his hand on a morse key. The light I had seen when coming down the field was on a post on the other side of the cart facing towards the winch.

So it looked as though 'Pop' was really going to try and fly this overgrown model aircraft.

'Oh well,' I thought, and crouched on my haunches to watch the phenomenon.

'All clear above and behind?' shouted 'Pop', his pipe gripped between his teeth.

The 'batman' screwed his head around looking up at the sky.

'All clear above and behind,' he confirmed.

'Pop' raised his left hand and prodded an index finger skywards.

'Take up slack,' he commanded.

The 'batman' began waving his bat to and fro' beneath his waist, and the man with the morse key began tapping, relaying the signal to the winch driver.

After a few seconds delay the cable slithered slowly through the grass and became taut, and the nose of the orange and white 'Tutor' began rocking up and down.

'Pop's' index finger was suddenly joined by the next finger and both fingers waggled to and fro.

'All out,' he called, and the 'batman' waved the bat above his head yelling: 'All out,' as he did so. The man on the morse key began tapping faster, and exhaust fumes from the winch on the hill began to rise.

The 'Tutor' lurched forward gaining speed, and the girl on the wing tip was running and holding the wings level. She suddenly let go and the little orange 'coffin' continued to run along the ground before, it too, floated quietly into the sky and pulled back into the same sickening climb, becoming smaller and smaller as it was swallowed by the pale blue sky.

I saw the nose dip, the cable release and then watched 'Pop' bring the machine into a level posture, and slowly, ever so slowly, crab his way along the ridge of downs, as he kept the small glider in the upcurrents from the wind beating against the hill.

On reaching Bo-Peep hill and the hangar, where the gliders were stowed during the week, he would turn, fly along to Firle Beacon, turn back and repeat the whole process over and over again, some-



times rising up in the air currents and sometimes going down slightly in the corresponding sinking air.

After about a quarter of an hour the little orange 'coffin' began to lose height and eventually 'Pop' turned it down wind, and the glider became larger again as it approached my end of the field. I watched it go past me at about 200 feet, screw itself round into a turn and come floating in over my head, to level itself off and kiss the grass gently before coming to a halt and dropping one wing tip on the grass. 'Pop' undid his straps and nimbly sat on the side of the cockpit awaiting the retrieve crew.

While I waited for him to return I looked around at the other gliders, some of which even had cockpit canopies and seemed to be more fully instrumented than the frightening little 'Tutor' that had immediately put me off the thought of gliding.

I investigated the large two-seater that I had seen launched on my way down the field a little while before, and heard someone refer to it as the '21', whatever that meant.

It was larger than the 'Tutor', but the cockpit was just as exposed though slightly more instrumented, and the controls appeared a little more business-like. The seats were side by side, the controls being fully duplicated for training purposes. The fuselage was a deep cherry red and the wings huge, fat and white with two *day-glo* panels amidships of each wing. The tail was small and white while the fin and rudder were tall and red. The wings were held by a fairing behind the cockpit, and two large single struts supported them from the base of the fuselage sides. 'Pop' joined me eventually, and I must confess I felt a bit surprised at seeing him in one piece and all smiles.

'Not a bad little flight,' he said in understatement.

'Thought you were about to meet your Maker,' I confided.

'Didn't meet him,' said 'Pop' lighting his pipe, 'only saw him, from up there.'

'Frankly, I'm in no hurry to do either,' I said emphatically.

'Once you've flown full-sized gliders,' he went on, 'you'll never do anything else. . . . You'll never do anything else,' he repeated.

'I wouldn't lay money on it, 'Pop'. It looks bloody dangerous to me.'

'Same as model aircraft,' he commented, enveloping me in a cloud of lung-scathing pipe smoke.

'Except that you are not *in* a model,' I corrected.

YOU'LL NEVER DO ANYTHING ELSE

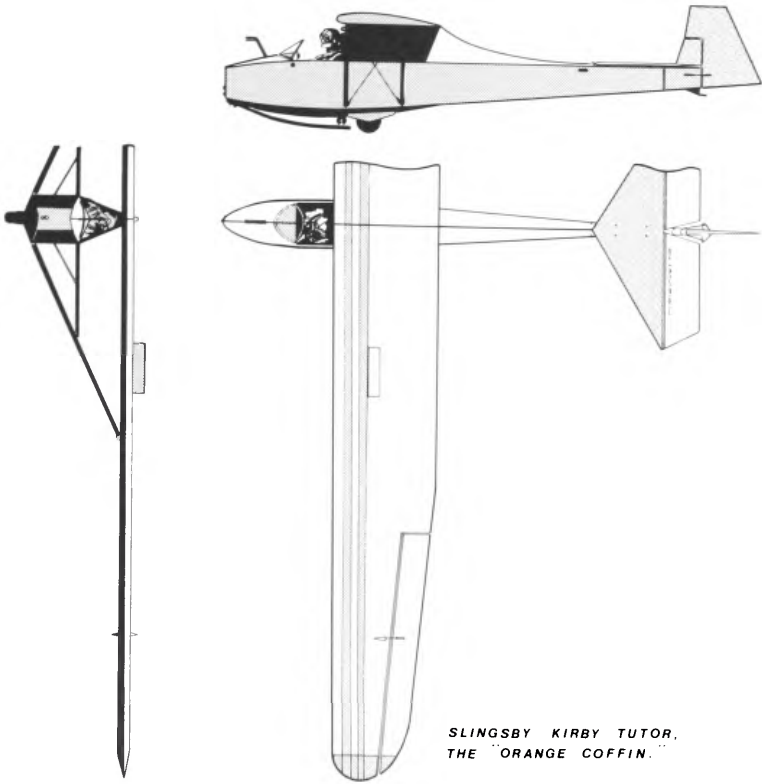

SLINGSBY KIRBY TUTOR.  
THE "ORANGE COFFIN."

'That's the only trouble with 'em,' he countered.

I leaned against the cockpit of the '21'. 'Don't people get killed flying these things?' I asked.

'Sometimes,' agreed 'Pop, 'but then people manage to get killed doing almost anything . . . or even nothing at all,' he added wisely. It seemed futile to suggest that I was 38 and a little too old to start flying, as I knew what his comment would be.

'Well, I don't know,' I mused again, looking into the cockpit of the large red trainer, 'I don't think this is for me somehow.'

'Course it is,' he said confidently, 'you'll find it's the greatest experience in your life, and you'll never do anything else,' he repeated.

I made the fatal mistake of taking a further interest in the subject, when I possibly should have turned on my heel and left the field forever.

## GLIDER PILOT

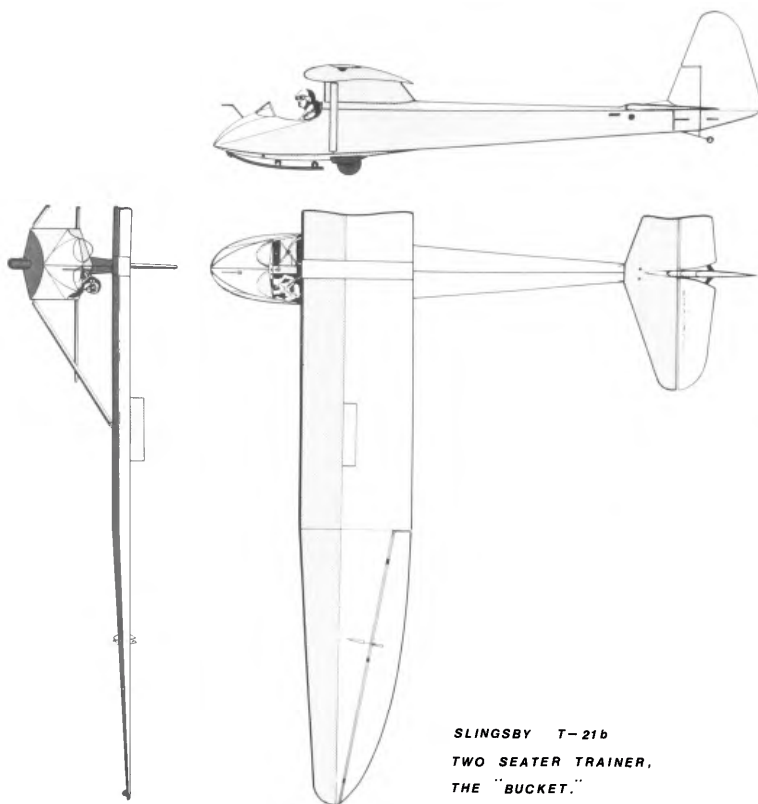

*SLINGSBY T-21b  
TWO SEATER TRAINER,  
THE "BUCKET."*

'How is it some of the gliders stay up and some come back after a couple of minutes?' I asked.

'A glider,' he informed me, 'is always descending in its own parcel of air. It is only when that air is going up that the glider can go up with it, and then that air must be going up faster than the glider is sinking. The glider pilot is searching for rising air and some find it and some don't.'

'How long does it take to go solo?' I asked.

'Well you've been building and flying radio-controlled models for years,' he reminded me, 'so with your knowledge it'll take you no time at all. What you need is some intense flying training, though. I'll see if I can get you signed up for club membership and get you on

YOU'LL NEVER DO ANYTHING ELSE

a summer course. We have three or four of these every year, and it means you can get a week's flying in and log quite a few flights. It'll bring your flying up to scratch very quickly.'

'What will it cost?' I enquired.

'£10 club membership and £4 joining fee. The flying is four shillings (20p) a launch up to ten minutes, and then so many pence per minute after that on a *pro-rata* basis. There is a waiting list for membership but if you come and worry the life out of them every weekend you'll soon get your flying in.'

'I still don't know if I should like it,' I said thoughtfully.

'Pop' turned on his heel and emitted a shrill whistle.

'Ken,' he called out to a tall thin man in flying overalls.

The thin man came over to us.

'This is Ken Pirelli, and this is Peter Champion,' he said, introducing us.

My stomach turned over as 'Pop' added: 'Give Peter a passenger flight in the "21" and see if he likes it, eh?'

'Haven't got time today, "Pop",' he said, and I thanked God that he hadn't, and turning to me added: 'Try next Saturday and I'll fly you round. Ever flown in gliders before?'

'No,' I said.

'You'll like 'em,' he grinned.

'Yes,' confirmed 'Pop'. . . 'You'll never do anything else.'

## I began to feel sick and dizzy

---

The following Saturday the wind was blowing at Force 6 on the Beaufort scale and the air was unstable. This meant that there were strong up and down currents in the 25 mile-an-hour winds, as the scudding cumulus clouds would have suggested had I taken the trouble to look up. But I was deep in thought on arrival at the gliding club for the second time in my life, and completely oblivious of the unfavourable conditions for a 'first' flight.

After much inquiry among busy members attending to a large number of gliders being launched one after the other, I discovered Ken Pirelli sitting on the grass eating some sandwiches protected from the wind by a stack of spare tyres.

'Peter Champion,' I smiled down at him.

He looked up, stuffed a large sandwich in his mouth and said (I think): 'Oh yesh . . . new bloke . . . pashinger flight, ishn't it?'

'Mm,' I nodded, and crouched beside him.

He produced a red folder from beneath his backside and thrust it in my hand.

'Indemnity form,' he said, 'fill it in and shign it. It'sh only in cashe you kill yourself,' he smiled, swallowing the sandwich, and added:

'Or more correctly, old boy, if we kill you, it states that your wife and dependents won't take action against the club.'

'I should think it quite likely that they would,' I replied somewhat upset by this total disregard for my life. After all, I thought, I'm no Tony Curtis or Rock Hudson, but I am all I've got.

'Fill it in anyway,' he grinned. 'After all old man, if you snuff it you

won't be around to know what they'll do. It's only a formality: I'll be flying with you and I don't intend to turn my toes up yet. Here . . . want a pen?"

I signed the wretched form with a shaking hand as the wind tore at the sheets of paper.

'While we're waiting for the "21" to come back I'll explain to you what goes on,' said Pirelli.

'Thanks,' I said, somewhat sarcastically, and handed him back his pen.

He sipped some hot coffee from a flask and began: 'Basically, old man, we have a field and a wind blowing down the field. We have a glider at one end facing into the wind and a winch at the other end on which is about 3,000 feet of steel cable wound round a drum. A tractor tows the cable out from the winch to the glider and the cable end is then attached to a towing link on the glider. A "body" holds the wing tip up and hence the glider level on its one wheel and as the signals for taking up the slack of the cable are given, the winch driver reels in the cable on the drum through his diesel-powered winch. When the pilot gives the take-off or "All out" signal, the winch driver speeds up the drum and the glider starts to run along the ground with the body on the wing tip running like the clappers until the glider outstrips him. All right so far?"

'Yes,' I said.

'Want a mutton sandwich?' he invited.

'I don't think so thank you.'

'To continue then,' he said. 'The glider then has air flowing over the wings to support it, and over the controls to make them effective, and therefore it rises slowly from the ground and the pilot holds it fairly level for the first hundred feet or so. This is in case you get a cable break low down where you want to have the glider in a level attitude so that you can land right away. Only when you have a hundred feet or so do you start pulling back and climbing at about 45 degrees and about 55 knots. You then go up in a large arc until at the top where the cable will start to pull your nose down again and the glider is once again in level flight. You then dip the nose, to release the tension on the cable and pull the yellow knob twice to make sure you have got rid of the cable. See?"

'I see.'

'Good,' he nodded, and sipped more coffee. 'Now several things can go wrong on the launch,' he said, comfortingly. 'It can be too

## GLIDER PILOT

fast for the designed launch speed, in which case the pilot waggles the tail left and right, or if it is too slow we rock the wings up and down (*Note: a method no longer allowed*), and the winch driver will try and either slow down or speed up the launch, depending on which is required and signalled. If we get a cable break on the climb we get the nose down in a hurry or else the glider can stall or even spin in if left with its nose in the air. Are you with me?’

I told him that I was. I didn’t tell him that I was beginning to wish I weren’t. . . .

‘Having got to the top of the launch,’ he went on, ‘we now fly a square circuit so that we arrive back at our take-off point, and we start this circuit when we get down to about 500 feet, so that until that time we can fly within reason anywhere around here, and if we get into rising air we can fly further away. Eventually, the conditions will deteriorate, and we must place ourselves in a good position up wind to start our landing circuit from a good height.’

‘I see,’ I said again.

I heard a loud rushing noise and was in time to see the ‘21’ landing with the spoilers extending from the wings. The latter vibrated like violin strings as the glider bounced on its single wheel, became airborne for a few more seconds, and then bounced twice more before slithering to a halt. It had dug one wing tip into the ground and cartwheeled half a circle round it.

‘Not a very good landing that one,’ commented Pirelli.

I was then aware of a man with a bat swishing above his head, and a sleek red and silver single-seater scudding across the grass and clawing its way into the air. At the same moment yet another glider, a blue one this time, was pushed into position for the next launch.

The ‘21’ was retrieved by a number of blue-overalled club members, and after the launch of the blue glider, pulled into the launching position.

‘Come on,’ said Pirelli, stuffing another mutton sandwich into his mouth and jumping to his feet, ‘this is our turn now.’

I swallowed, stood up, and began to follow his long steps across the grass, noticing the blue-overalled bodies holding the nose of the machine down against the force of the wind. A wing man was already holding the wing tip with both hands as the wind tugged and rocked the 54-foot span wing.

Ken Pirelli went to the left-hand cockpit and patted the large red nose of the machine.

## I BEGAN TO FEEL SICK AND DIZZY

'This,' he began the introduction, 'is the Slingsby T-21b or Sedbergh, or as we irreverently refer to it, the "bucket". Climb in,' he invited, 'but watch where you put your feet and don't grab the windscreen.'

There followed a myriad of instructions of 'don't do this' and 'don't put your foot through that', as willing helpers assisted me into the right-hand cockpit and Pirelli took the seat next to me. He strapped himself in, and another willing helper pulled up my seat straps and two more over my shoulder and fitted all four into a common lock. Then they were adjusted until the fit was tight and my bottom pressed hard onto the unforgiving wooden seat.

'What about parachutes?' I asked Pirelli.

'What about them?' he replied, twiddling little knobs and tapping the instrument panel.

'Don't we wear them?' I asked, already feeling somewhat nervous.

'Not in the "bucket",' he answered, 'it isn't built to take them, and anyway we should not be high enough to be able to use them even if we wanted to.'

I felt doomed.

'Now first of all we complete a cockpit check at the beginning of every flight. These checks follow a pattern. First, the controls for full and free movement,' he went on, pushing the stick this way and that at the same time pushing his feet on the rudder pedals. The T-21 lurched as the high wind took immediate effect on the controls, and the helpers held on even more tightly.

'Then we check the ballast, or the loaded cockpit weight. How much do you weigh?' he asked.

'About eleven stones,' I replied.

'One hundred and fifty-four pounds, and I am around one hundred and sixty . . . making 314 pounds in all,' he went on, checking a small placard on the side of the cockpit. 'We have to make sure our combined weights are not below a certain figure listed here,' he said tapping the placard, 'and not more than the maximum listed. Now are your straps on tightly and secure?' he asked.

I tugged at the wretched things.

'Yes,' I said.

'Good. Now we always set the altimeter at zero with this little knob under the dial so that we can know how high we are above our launch point. We re-set the "G" meter, and switch on the turn-and-slip indicator. We would then set the tail trimmer if we had one,



but as we haven't, we can't.'

'Is that serious?' I asked.

He regarded me with contempt and went on: 'We would then check the canopy if we had one, but as we haven't, again we can't, and that's not serious either,' he added.

'Now, finally, we check the spoilers or brakes. On the "21" we have spoilers and we pull them open with this blue handle,' he continued, yanking back the handle and calling out to the wing man: 'Spoilers open and in line?'

'Open and in line,' came back a squeaky little voice, and he eased them shut again.

'Squeaky-voice' called out: 'Closed and flush.'

The tractor was speeding towards us carrying the steel cable, and our launch run today was different from those I had witnessed the previous Sunday. Then 'Pop' had launched from the bottom of the field up towards and over the line of hills at the top of the field. Today they were launching along the crest of the downs from Bo-Peep hill to Firlie Beacon. So that in addition to the launch height, there would be an awe inspiring drop of 400 feet as the downs fell away to the valley below, to our right.

I placed a knitted woolly hat on my head and slung my camera around my neck. If I was to survive this ordeal I meant to record it on film at any rate.

The cable was brought from the tractor which sped off back towards the winch ready for the next retrieve, while a woman with grey hair leaned down with the end of the cable ready to attach it to the towing hook.

'Open,' called Pirelli, pulling back the yellow wooden knob similar to the duplicate that was fitted on the instrument panel in front of me.

'Closed,' said the woman, and Pirelli repeated: 'Closed', and let go of the yellow knob.

The cable was attached to the tow hook of the T-21 and I felt even more helpless than when I had first climbed into the 'bucket'.

The wind stung my face, and although early summer, the air seemed cold and hostile, with the low cumulus clouds scudding across the sky at what seemed tremendous speed and rapidly changing shape as they did so. The blue overalled pilots who had assisted me into the cockpit were suddenly nowhere to be seen, and an ominous-looking signaller with a bat at the ready stood by on our

starboard bow.

There was a four-sectioned windscreen bent around the front of the cockpit, and I huddled down behind it leaning forward against the creaking shoulder straps. The take-off run in front of us was barren and uneven and the tiny blob of the winch only just visibly perched on the Beacon.

'Here we go,' said Pirelli loudly through the wind.

I swallowed and the cold seemed to leave my body, to be replaced by the heat of tension and excitement.

'All clear above and behind?' enquired Pirelli of the waiting 'batman'.

'Batman' searched the sky and shouted that it was all clear.

'Take up slack,' commanded Pirelli, raising one finger. The batman started his signal, waving the bat to and fro, and the morse tapper flashed the signal light to the winch. I watched the steel grey cable slither through the grass in front of me and go straight and taut.

'All out,' came the final shout, and the pilot waved two fingers above his head.

The batman relayed the command and waved the bat above his head. Almost simultaneously the cable began to drag us forward. I looked out to see the wing man, running as hard as he could, and suddenly disappear as we accelerated along the bumpy ground. However, with a couple of minor thuds we were off and rising rapidly as Mother Earth slid quickly away beneath us, with me tugging at her apron strings in the only way left—by hanging grimly onto the wooden side of the cockpit with both hands.

We were rapidly at 150 feet in the high wind. The 400-foot drop over the side of the hill was all too plainly visible and my stomach revolving. This was only to be accentuated by Pirelli suddenly pulling us steeply into a 45-degree climb, which made me turn my head to the front. Looking through the windscreen, where seconds before I had a panoramic view of the downs, I now had only sky and speeding clouds ahead of me.

The airflow suddenly plucked my woollen hat from my head and whipped my hair in front of my eyes, as with hat and courage now both over the side we climbed quickly in the rocking and bouncing glider. As we came to the top of the launch Pirelli busily moved the stick and rudder pedals trying to keep the machine straight and true in the turbulent air. The cable began to pull the nose down and the glider was on a level keel for a few seconds, though not long enough

for any comfort. He eased the stick forward into what felt like a vertical dive, pulled the yellow knob twice, and I felt the glider now free of its burden leap into the air only to drop swiftly into turbulence.

So we continued on our course along the hills, up and down, like some giant puppet on rubber strings, bouncing my stomach into my throat and then pushing my head through my boots. The sudden grip of ice-cold fear seized me, and the only thoughts that sped around my brain were those of getting down and surviving.

Pirelli was talking loudly through the noisy airflow but his words were lost forever in my concern for self-preservation. I thought I raised my camera once or twice, but then was unsure whether or not I had done so, only to be subjected to fresh surges of panic as he dipped one wing and we flashed round in an eye-ball swinging turn. 'A little choppy,' shouted Pirelli, and looked at me and smiled.

I looked out at the enormous wings and the long white struts and my heart sank as the wings flexed and bent, groaning as they did so like some ancient China Clipper trying to round the Horn. The open cockpit gave no feeling of protection but seemed to thrust one into the elements, and my fingers dug deeply into my straps as Pirelli said excitedly: 'Lift on the vario... look... we're going up...'

Sure enough the wretched little vario had a green ball bobbing up and down in the long thermometer-like tube and the altimeter jerked its needle up to the 1,000-foot mark and beyond.

'Good... good... ' said Pirelli, nodding to himself, 'we only had an 800-foot launch. We're doing well.'

He kept the horrible turn going, and we spun round and round until I was completely disorientated. The swirling land below could have been China or Peru for all I knew or cared.

There was the sudden impression that the wings had dropped off and we felt as though we were dropping through the air. I gasped and looked at the little variometer. The green ball was now at the bottom of the tube, but in the twin tube next to it a red ball shot almost to the top.

'Bloody sink' commented Pirelli as we hit more turbulence, and I began to feel sick and dizzy.

Suddenly he straightened the T-21 out into a more or less level flight path and jabbed his finger over the side of the cockpit.

'Down there,' he shouted, and I looked over the side but could only see an unidentifiable mass of green fields.

## I BEGAN TO FEEL SICK AND DIZZY

‘The wind has drifted us back almost over the launch point, so we’ll have to forge ahead up wind again. How do you like it?’ he asked.

I had by now given up all hope of ever seeing the ground and being in once piece again, and not only was I expected to suffer this torture but the torturer wanted to know if I liked it.

‘A thrill a minute,’ I shouted truthfully.

‘Do you want to try the controls?’ he asked.

I was still doubtful whether this albatross of a man could return us both to earth safely, but I was quite certain that any efforts by me to try and control this beast could only end in disaster. I shook my head negatively.

‘You don’t know what you’re missing,’ he shouted.

‘No mate,’ I thought to myself, ‘and neither do you.’

By the time we had flown back to the Beacon we were down to 800 feet, as the air continued to pick us up and drop us down at erratic and violent intervals. I picked up my camera thinking that some form of concentrated activity might save my reason, but could only see a blurr of landscape through the viewfinder as I pressed the trigger with a cold and shaky finger. Again that wing dropped, and we described a steep and frightening turn. I dropped the camera as I gripped the sides of the cockpit, the camera swinging this way and that from the lanyard around my neck.

Further words from Pirelli were lost as panic seized me yet more violently. Everything that was happening now seemed terribly fast and unreal. We executed another turn, mercifully not executing ourselves, and I saw that we were over Bo-Peep Hill whipping into another steep swerve that lined us up for our landing approach. The turbulent air was now rocking the glasses on the end of my nose, which made me wonder whether or not they were going to join my woollen hat. I grabbed them and pressed them close to my face as Pirelli kicked out at the rudder bar and fought with the ailerons to try and steady our approach.

The T-21 bounced around the sky in even wilder gyrations as the landing field snaked up towards us, slowly . . . ever so slowly, while Pirelli suddenly pulled out the spoilers and eased back the stick a little and we began to sink quite fast. When it seemed we should fly straight into the ground he eased back a little more on the stick and we were flying straight and level only a foot above the blurred green of the grass.

Eventually the thing floated to the ground, and with just one

spine-shattering bounce, came to rest only feet from our take-off point, hovering in the wind quite level before slowly depositing one large wing tip on the ground. I took great lungfuls of cold air through my cracked and dry mouth and felt the perspiration around my neck suddenly go sticky and damp from the wind. I was aware of Pirelli looking at me and heard him saying: 'Fancy another one?' 'You have to be Bob Hope,' I said, rather rudely, and he looked quite puzzled.

'You *do* look a bit green,' he replied, and turning to the approaching retrievers shouted: 'Whose next for the "21"?''

'Lunatics and suicide cases form up three deep,' I muttered under my breath, and suddenly pairs of helping hands were undoing my straps and helping me out of the cockpit.

The fact that we had returned to earth without killing or maiming ourselves and with the red and white 'bird' completely unbroken took some seconds to sink in. Pirelli too, climbed out and slapped me heartily on the back.

'Must go for a pee,' he said. 'If you want one, over there behind the gorse bushes,' he added, jabbing a finger in their direction, 'but for God's sake don't do it against the wind, or you'll get yourself into a hell of a state.'

The T-21 had already been wheeled back to the launch point and the next pupil was getting himself strapped into the beast. Pirelli slapped me once more on the shoulder and stomped off towards the privacy of the gorse bushes. Thankful to be alive I avoided all other likely looking characters who appeared to be coming towards me, welcoming me to the club, and quickly made my way to my car. I drove home conscious only of the shock and fear I had experienced and furious at myself for the cowardice I had felt if not fully exhibited.

As I shut the front door of my house I saw a letter on the doormat. I opened it. It read: 'I am pleased to welcome you as a Member of the Southdown Gliding Club and to inform you that I have been able to put your name down for the week's flying on the August Course.' I screwed up the letter and threw it across the hall.

---

## Is your number up?

---

The one single factor that had acted as inspiration for me to take up gliding had been the film *Those Magnificent Men and Their Flying Machines*, with the beautiful aerial shots synchronised with the low-flying speeds of the aircraft of the era. Shortly after my first disastrous flight I had seen the film for a second time, only to be re-inspired all over again. Commonsense quickly came to my aid in pushing the fears of my first flight to the back of my mind. I felt that it was utter foolishness on my part to feel so frightened of flying while men like ‘Pop’ Orford could accomplish it at the age of seventy-one, and at the other end of the age-scale many teenagers enjoyed the sport.

I also possessed a romantic idea about aircraft and pilots that had dove-tailed into manhood from my schooldays during the ‘Battle of Britain’. I recalled names like Malan, Bader, Finucane (whose passing I mourned with as much profound grief as that of a close relative), and later Gibson and Johnson, with more poignancy than I felt for Shakespeare and Pythagoras.

I have always subscribed rather too heavily to the swashbuckling and rebellious outlets in life, and the thought of becoming a glider pilot seemed to manifest all the childish possibilities of a life-time into one dramatic sport.

Full of good intentions and great ambitions I joined the summer course for a week’s intensive gliding. In addition, to ensure that I left no loop-hole for retreat, I paid the necessary £14 to join the club and a £2 deposit for the course.

As dawn broke in a cloudless sky on the first day, the 20-odd

## GLIDER PILOT

course members and four instructors sweated and broke their backs levering the four gliders out of the hangar at the top of Bo-Peep hill. First the tractors and the diesel-powered winch were oiled and fuelled. This was followed by the extraction of the giant T-21 from the hangar, and before we seemed to have got our breath back 'Tutor', 'Swallow' and 'Olympia' were manhandled out onto the damp green grass to undergo the compulsory daily inspections to ensure that the gliders were safe and airworthy. At the same time the tractors and the winch were checked for satisfactory functioning. I was in a hurry to get started, but George, the Chief Flying Instructor, was determined that everything should proceed in a slow, quiet and orderly fashion. I pummelled his brains with question after question, ensuring that at least I established *my* enthusiasm.

The winch was finally placed in position at the top of the hill, giving a launch from the bottom of the field at right-angles to the line of the downs. This allowed the gliders to cast off the cable over the summit of the hills, enabling them to make full use of the wind that rushed up the slope, and so sustain them in the continual up-currents. The gliders were towed and manhandled from the hangar to the bottom of the field at a snail's pace. It seemed that gliders are notoriously weak and subject to damage on the ground, while they are immensely strong in the air, even on the most violent of days, so towing them across uneven bumpy ground is best achieved as slowly as possible. I was unaware at this time that the gliding site at Firlie was one of the more notorious in the country, full of hills, valleys, pitted ground, sheep and cattle: not to mention the 'orographic' cloud which forms suddenly and quickly on such hills. In its unkind way the sea, which is only five miles distant, can send in a stream of cold air around mid-day and literally change the wind direction through 180 degrees. This slays any existing thermals in one fell swoop, and any unsuspecting glider pilots to boot, who have failed to notice the change in wind direction.

The towing cable was inspected and laid out ready for the T-21 to make the first flight of the day. While the other gliders made their weary progress to the launch point, the '21' was lined up, a pupil inserted together with an instructor, the cockpit checks completed and the cable release mechanism checked on the glider. The signal cart was positioned, and a wingman all ready holding the wing tip of the '21'.

## IS YOUR NUMBER UP?

A batman made the signals to an individual stationed at the signal cart who relayed them to the winch driver. The T-21 swished across the grass on its ground run, rose a few feet into the air, gradually ascending to just over 100 feet before going back into the climb towards the clear blue summer sky. It was 08.45.

Life, I thought, was extremely good as enthusiasm and excitement welled up inside me. I made my first real contacts with the other course members and we shared our meagre triumphs, ambitions and fears. I was overawed to learn that some comparatively new members had already achieved the staggering total of over 20 flights and that one youngster had already experienced aerobatics in the form of loops and 'chandelles'. The chandelle was executed, it seemed, by diving the glider, pulling back into a climb and then putting one wing down and literally turning the glider to fly back down its original ascent path into another dive whereupon the manoeuvre could be repeated.

One character, who appeared quite above the rest of us, aeronautically speaking, had rejoined the club after a year's absence and talked incessantly of spins and stalls and the recommended manner of curing them.

There was no mention of what one did for a living, and I was quite oblivious of whether I was addressing lorry drivers or company directors, as the conversation started with flying and was to continue with flying for the rest of the day.

Flying has, for all its joys and wonders, a spiteful habit, like a small puppy, of biting you when you least expect it. It generally chooses a moment when you are in great spirits and feeling on top of the world; like many a doomed army singing its lungs out completely unaware what lies over the brow of the next hill.

Such was the moment when I climbed into the T-21 that day for my second excursion into space. The previous pupil had completed three flights: merely three short training circuits, as the wind on the hill had yet to reach sufficient proportions to sustain any glider. I was the next on the list.

Barry, tall, lean and hardly grey at all for all his middle fifties, instructed me in cockpit checks and take-off procedure; and before I had mentally registered the functions we seemed to be off, cutting across the grass only a foot or so aloft, with the cool early morning summer breeze stinging our cheeks. The straps bit tightly into my legs and shoulders, the result of adjusting them with little ex-



## GLIDER PILOT

perience and great gusto.

Barry eased the stick back into his stomach and the T-21, or the afore-mentioned 'bucket', rose at an angle that would have done justice to an Apollo moon-launch, sending its two occupants in an arc 800 feet up over the line of downs. The nose dipped after our return to a level attitude and Barry pulled the cable release twice, reducing the glider from a speed of 55 knots to 40 knots as he eased it into a level attitude once more.

I looked over the side, and with the suddenness of a rifle bullet I felt a wave of panic and nausea sweep through my body as though I had dived into an icy pool. The ground seemed miles away, the open cockpit offering little protection from anything the elements might care to inflict on us, and the sensation of suspension could only be described as hanging from the Post Office Tower by one's braces. The fact that the Slingsby T-21b was manufactured by a great company and had been tried and tested over the years, allied to the fact that my instructor had had many hundreds of flying hours and as much survival instinct as myself, inconveniently escaped my attention at the time.

*Inexperience is the handmaiden of panic, and panic is the father of mistakes.*

So wrote Erich Hartmann, the great German fighter pilot who survived World War Two. My first reaction to the engulfing panic and fear was to get out of the wretched aircraft and forget all about gliding for once and for all. But flying has another spiteful habit of allowing you to place yourself in a dangerous or unenviable position, and insisting that you sort it out, if you are indeed to survive.

Unlike learning to drive a car, where if things go frighteningly wrong for a few seconds, you can slam on the brakes, switch off and get out for a breather and a stroll, while you sort out some of the problems, flying is a far more demanding mistress. However, it will, in time, make you a more resourceful and self-reliant person.

As our 800-foot altitude prevented me from getting out of the glider, I tucked my face down behind the windscreen and gripped the wooden side of the glider with great strength. My enthusiasm and great intentions of but a few seconds previously were now dashed to the ground, as if I had physically been able to throw them over the side of the cockpit. It seemed as certain as the sunrise that gliding held no future for me as a sport, or even as a mere grinding accomplishment. I hated the sensations and longed only to get my

## IS YOUR NUMBER UP?

shaking little legs back onto Mother Earth with as much speed as possible.

I had felt similar emotions when flying with the Air Training Corps during the war years, but that was a long time ago and in the following 20 years had experienced a severe nervous breakdown coupled with agoraphobia, or fear of open spaces. This was a double condition of affairs that had persisted for a year and taken about four years to overcome completely. While it would have been a simple matter to convince myself that these panic symptoms of the moment were in some way connected to my former state of mind, I felt certain that they were not, and merely another hurdle in life which at this point in time appeared insurmountable.

The 'panic' was increased like an additional surge of electric current as the wing of the '21' dropped and Barry executed a series of shallow turns. I promptly leaned the other way, trying vainly to balance myself into some form of level equilibrium, as the landscape became a whirling mass of green circles, disappearing horizon and flashes of sunlight.

'What manoeuvre would you like to experience next?' asked Barry. The panic had me by the throat, as the swirling mass of landscape whirled in front of me until I could stand it no longer.

'Landing . . .' I answered through a dry mouth and chattering teeth. He straightened up the glider into level flight and nearly stalled it from surprise at my answer.

'Feeling dicky?' he queried with some concern.

I nodded, gulping great mouthfuls of air into my lungs.

'Strange,' he commented. 'Is it the turns that upset you?'

'Together with the take-off, the straight and level and the landing,' I informed him. 'Apart from that I love every second of it.'

He was not amused by my wit.

'Are you sure you wouldn't like to try something else?' he asked.

'Only the landing,' I repeated, sounding like Captain Flint on Long John Silver's shoulder.

He shrugged as much as his shoulder straps would allow, and with some justifiable annoyance slammed down the wing of the '21' and turned down wind, pulling the large handle to open the spoilers and fly off some of our excess height.

With the landing circuit in operation the panic subsided slightly, but the turn at the bottom of the field to take us across wind disorientated me still further and our final turn into wind was both

steep and fast. Then with the grass sliding past us I heard the comforting rumble of the main wheel making contact with the earth, and we were down. The thing ground to a halt and dropped a lazy wing tip onto the grass as we sat there in silence for a few seconds before Barry muttered: 'Well . . . I don't know.'

I opened my mouth to say something and shut it again. Words, in my experience were fairly cheap, and if they could not be backed up with corresponding actions they merely constituted a waste of breath, and as I had little of that commodity either a heavy silence fell upon us.

We did eventually vacate the cockpit and having landed a few hundred yards from the take-off point it was a little while before willing pairs of hands came to our assistance. To make matters worse other members were asking me how I had enjoyed it. I looked at my watch. The whole flight had lasted just over two minutes. Two unbelievably, panic-stricken, impossible minutes.

It is normal to fly a pupil on two or three consecutive training flights in order to give him some continuity in his educational experience, but Barry walked away from the glider once it was parked and called out for the next pupil. While the next eager pupil was strapped into the 'bucket' I noticed Barry chatting to George, the Chief Flying Instructor.

I disappeared behind some gliders and found my hold-all containing food and a newspaper. I sat on the ground in the warm sunshine and scanned the back page which contained among other things, a list of Premium Bond winners. It was headed:

'Is your number up?'

The paper was pushed back into the hold-all and I got up and walked towards George and Barry who had been joined by another instructor. I overheard their conversation from behind another parked glider. Eavesdroppers never hear good of themselves, or so they say, and I was to be no exception.

'Sounds like bloody cowardice to me,' maintained the third instructor.

'Don't know,' mused George, thoughtfully.

My heart sank. I wished I were dead.

'I don't think so,' said Barry (to the rescue), 'I think it's possibly that he lacks flying experience and is a bit imaginative. What are

## IS YOUR NUMBER UP?

you going to do about him, George?’

‘I’ll let you know,’ said George, flatly, like a magistrate considering his verdict.

‘Morning, Peter,’ said a deep voice behind me, and I turned somewhat surprised to see the speaker was a large woman in tight-fitting red, white and blue trousers. I knelt on the grass and looked up at her oval face that peered down through the outline of a huge bust.

‘Put you ’orf a bit, did it?’ she asked in a cultured voice.

‘Somewhat,’ I replied, in careful understatement.

She ran a chubby hand through her grey hair.

‘You can get used to anything except hanging,’ she stated with a loud laugh.

‘Including “hanging”, from a T-21,’ I added.

‘Indeed . . . indeed,’ she chortled, and made her way towards the three instructors.

Another figure joined me: short, male, early forties with crinkly brown hair, clipped military moustache, and brand new, blue flying overalls.

‘David,’ he said, grabbing my hand and pumping it up and down.

‘New member, old boy; come to slay my Goliath too.’

I introduced myself, and David regarded the retreating figure of the large woman with raised eyebrows.

‘Looks like a walking deckchair,’ he commented, and turning to me:

‘Your flight upset you?’

‘Mm,’ I nodded.

‘How many have you done?’

‘That was only my second,’ I said.

He knelt down beside me. ‘Second one’s always worse than the first,’ he claimed. ‘I remember my first parachute jump, Special Air Service and all that, old boy,’ he went on, smiling. ‘The first one is a “doddle” because you don’t know what to expect and it’s all over so quickly. But the second jump’s a bastard, and if it weren’t for that bloody marvellous discovery called “whisky”, I’d never have done the third.’

I began to feel just a little better. ‘How many glider flights have you done?’ I asked him.

‘None at all yet,’ he said, and at last I felt I had found a lesser-experienced mortal than myself. ‘Couldn’t give a “monkeys” though, old boy: can’t be any worse than hitting the silk.’

## GLIDER PILOT

The conversation was interrupted as another member introduced me to the wonders of driving the cable retrieve tractor. After three hours of that I managed to squeeze out more perspiration in what now was a hot summer's day, in lugging the gliders back to the launch point over the unforgiving and rough ground. As the day wore on the gliders got heavier, and I was ready to give up at 6 p.m. when I was informed that they flew until sunset, which would be around 8.30 p.m.

I lost sight of David for the rest of the day, and as evening, hunger and tiredness approached the failure of my efforts at the beginning of the day flooded back into my mind. With the gliders safely inserted in the hangar and the doors finally closed I made my way in darkness to the car park. Leaning against the door of my car was George. I never did discover how he found out which was mine, but there he was blocking the final exit for my escape. I walked towards his dim outline, trying to do so slowly and nonchalantly when I tripped over a piece of brick and went flat on my face.

He assisted me to my feet with the comment: 'Not your day?'  
'Doesn't seem to be.'

'Sorry about today,' he said quietly, 'but I've reached a decision.'

My heart sank. 'Have you?' I said, my mouth going suddenly dry.

'Oh yes,' he replied, 'I think it's quite clear what we must do. Did you know that early in the morning and late in the evening the air is generally very calm?' he inquired.

'I suppose so, though not consciously,' I replied.

'Well it is,' he smiled.

'Oh,' I said, rather stupidly.

'Well tomorrow, we'll fly you first thing in the morning and again, later in the evening.'

'Oh, I see,' I said, with equal stupidity, for 'see' was the last thing I did, and I just could not 'see' how I was going to overcome my own private hell, whether it be early morning or late evening or high noon.

'I'll see you early in the morning, then?'

'Yes, of course,' I replied, as we both stared, neither really believing the other.

---

## ‘You have control,’ said George

---

‘Good morning,’ said George with unconcealed surprise, as I arrived breathless after my half-mile tramp to the bottom of the field from the car park. It was still early and another glorious summer’s day with the air dead calm as George had predicted.

I had little doubt that on my previous evening’s departure it had been declared by one and all that would be the last they would see of me. In all honesty, on this particular morning I had not the slightest idea or even a good resolution of how I was going to fare in the coming day’s flying. I suppressed all thoughts of the consequences if I ‘muffed’ it for a third time in succession.

The T-21 was already lined up for take off and another pupil already seated in it was extricated after a quiet conversation with George, who then ushered me into the cockpit in his place. The other pupil, cheated of his flight, scowled at me as he passed, and for the third time in my life I clambered into the bowels of the ‘21’.

A gentle hush fell over the remaining course members as they slowly sidled up to the glider intent on seeing what sort of mess-up I would make of this effort. I had little doubt that they considered it justifiable entertainment.

George climbed in beside me and shouted quick instructions to the idle onlookers who dispersed and went about their allotted tasks. We strapped ourselves in and George did the cockpit checks, talking slowly and calmly as he did so.

‘I want you to concentrate on relaxing,’ he said, ‘and getting used to your new environment. I will do the take off and landing, but I

want you to keep your feet lightly on the rudder pedals and hold the stick with your finger and thumb. It is not necessary to grip it. When we cast off the cable I will say: "You have control," and I want you to try and keep the glider flying straight and level at a speed of 40 knots indicated on the A.S.I. with co-ordinated movements of the stick and rudder pedals. When I say: "I have control," I want you to cease trying to fly the glider and hand over to me. Keep a light pressure on the controls when I am flying it, and try and follow through with the actions I take so that you can learn to get the feel of the glider. Make all your movements, when you are flying, small movements, and make them as smooth as possible.'

'Yes . . . I see,' I answered. He looked across at me, and from his expression I could tell that he indeed wondered if I did see.

'The air is quite smooth,' he added, as the cable was attached to the towing hook, 'and you should not experience any problems. All right?'

'Fine,' I said, gripping the stick and stabbing my feet onto the rudder pedals.

'Finger and thumb only,' he corrected tapping my right hand. 'Don't grip it.'

I relaxed as much as I could.

Once more the cool airflow stung our cheeks as the '21' parted company with the grass and rose flatly, gradually pulling back and climbing into an arc as George eased the stick back into his stomach. I looked straight ahead at the clear sky determined not to frighten myself by staring down at the ground.

'Look out at the wing tips on the climb,' said George, 'and make sure they are level.'

I held the stick lightly and followed through his movements of the controls, looking out at the wing tips and noticing the layers of early morning mists in the valleys below.

We reached the top of the climb and the cable began to pull the nose down.

'Now we ease forward on the stick' said George, dipping the red nose of the glider . . . 'and with two definite pulls on the yellow release knob . . .' he yanked the thing twice . . . 'we get rid of the cable and throttle back from 55 knots to 40 knots . . . like this . . .' and the airflow ceased whistling in the struts and the glider felt level and balanced. 'I am going to turn right, now,' he informed me, 'by lowering the right wing with the ailerons and at the same time

‘YOU HAVE CONTROL,’ SAID GEORGE

applying a little right rudder to balance the turn.’

I felt the stick and rudder pedals move together and as I started to lean away from the turn George said: ‘Lean *into* the turn . . . as though you are riding a bike. Try to become part of the aircraft.’ Forcing myself, I leaned into the turn as George continued to explain: ‘In an open cockpit like this you should feel the airflow on the front of your face at all times. If it comes from the right in a right turn, then you are slipping the aircraft into that turn because you possibly haven’t enough rudder to assist the ailerons. If you have too much rudder then you are skidding the aircraft into the turn, and in a right turn like this you would feel the airflow coming onto the left of your face. Got it?’

We came out of the turn, and I felt the controls move as George straightened her up.

‘Got it,’ I said.

We flew at 40 knots along the ridge, with the nose pointing outwards slightly into the soft breeze.

‘You have control,’ said George, and I felt the controls go sloppy in my hand and the rudder pedals banged against my feet. The glider began to swing this way and that, and I felt my feet press hard on the pedals and my hand grip the stick as I frantically over-corrected. Suddenly the ‘bucket’ commenced a number of wild gyrations and George said calmly: ‘I have control.’

The ‘bucket’ suddenly behaved itself in George’s capable hands. I relaxed my vice-like grip on the stick.

‘You are over-correcting,’ said George, ‘possibly because you think the glider is balanced on a knife edge and will fall out of the sky if you don’t keep a tight rein on it. The glider is quite happy flying along without your help, so watch this.’ As I watched, horrified, he took his hand and feet from the controls. The T-21 dipped its nose slightly and the speed rose to 50 knots, the airflow increasing and stinging my face once more.

‘See?’ he smiled. ‘Quite stable isn’t it?’ and eased back the stick until we cruised once again at 40 knots. ‘You have control,’ he said, and once again I tried to fly the beast. ‘Now fly it hands and feet off,’ he commanded.

‘I’d rather not,’ I stammered.

‘Fly hands and feet off,’ he repeated but in a calm manner.

I let go of everything and awaited our demise.

The T-21 merely repeated the performance of increased speed



and a slight dipping of the nose. I became suddenly distracted by the beauty of the mists in the valley, as little villages and a church spire protruded from them giving the scene an air of unreality.

'Take control again,' said George, 'but pull back the speed gently.'

I worked feverishly to get the swine to respond, and although better this time the nose still swung from side to side as I kicked out at the rudder pedals like a mad church organist.

'I have control,' said George, and I sat back in the cockpit breathing heavily with the sweat running down my temples 'We're getting low,' he said and turned the '21' down wind.

As we rolled to a stop on the wet grass he said: 'Want another one?'

'Of course,' I answered, not really knowing whether I did or not, but determined to make some progress on the preceding day.

The flight had lasted four minutes: nothing at all really, but double the duration of the previous day's flight and although I had still been scared I had noticed some improvement. The love-hate relationship with flying had begun in earnest. I completed two more flights that day both of merely four minutes duration, and if George taught his erring pupil little else he did manage to get me to lean in on the turns.

The rest of the day was repetitious: driving the retrieve tractor and lugging gliders around until my back nearly broke in two. I drove home in the failing light: dropping my mentally and physically exhausted body into a heap on the bed and into the relief of sleep; only to wake at 6 a.m. the next day and repeat the whole performance again.

On this day I managed five flights, again with George in the next seat, and tried to get the 'bucket' to turn. More wild gyrations all over the sky as we slipped and skidded and did in fact every manoeuvre barring turning correctly. George then showed me slipping and skidding turns, and how *not* to do them, but still the '21' had a field day flying its stupid pupil just where it felt like. It took over like some wild horse aware of its nervous rider and determined to set off at a gallop.

At the end of the day I had completed a total of eleven flights. For all the sweat and effort my log read simply: '*Turns . . . lacking co-ordination.*'

On the Thursday it rained and we all spent a chatty time in the hangar as the pundits showed their meteorological knowledge and

‘YOU HAVE CONTROL,’ SAID GEORGE

prophesied when the weather would clear. It didn't. These wet days are quite valuable at times, as through the ensuing conversation which is 90 per cent flying and 10 per cent women, a great deal can be learned about the former and little about the latter.

I began to discover what a stall was and how a glider could spin: more important, how to recover from a stall and a spin. But I must confess the thought of such manoeuvres terrified me, and I began to feel like a man with wooden legs faced with a succession of hurdles that disappeared into the distance. Even assuming that I had overcome one, rather painfully, it seemed there would always be another. I reconciled myself to the fact that I would take them one at a time and not try to conquer flying in one fell swoop.

The Friday, and last day of the course was fine again, and once more I climbed into the Sussex sky, and even tried my hand at a launch and a couple of landings. I was as yet so inexperienced that I had little idea how to judge my performance. I decided they couldn't have been too bad. I deduced this from the fact that we had walked away from the landings and the launch had got us to 750 feet. Again I tried turns, and yet again the 'bucket' flew the pilot. In the screaming airflow I allowed the speed to increase to 60 knots. Then there came a deathly quiet as the nose went up, the speed fell off and the controls became 'mushy'. Finally, there was a buffet just prior to the stall, and the sudden awareness came over me of what was happening as I shoved the stick forward to unstall the glider, only to overdo the whole thing and wind up in another screaming dive.

During the afternoon I had chance to watch the efforts of some of the others, including David, who seemed to have less instinct than I when airborne. Also, his 'crutch-searing' approaches over the barbed wire fence provided much excitement and entertainment.

One of the great features about a T-21 coming in to land on a calm day is that those on the ground can hear every word spoken by those in the open cockpits as they flash by. As David made repeated efforts to land the 'bucket' in some semblance of order I could hear the instructor say: 'I don't know what you've got hold of David, but it certainly isn't the stick. . . .'

And on another occasion: 'If you're in such a hurry to die . . . do you mind doing it somewhere else?'

And finally: 'Steady . . . steady . . . I have control . . . *I have control. . . .*' While a voice next to me muttered: 'Thank Christ someone has control.'

## GLIDER PILOT

By the late afternoon I had a total of 19 flights to my credit or discredit, depending on your point of view. I embarked on my twentieth with George next to me, and just a slight beam of confidence as he told me that I was to concentrate on the landing. Circuit planning is by far the hardest part of learning to glide, as the machine, absent of any engine must be placed in a desirable position from which to execute the landing. This means that the mental picture of a square circuit placing the glider at suitable heights at each corner of the square, is by far the easiest method of completing the flight and landing properly.

The ridge towards which we were launching was some half mile distant, and a launch of some 800 feet meant that we could cruise around using up our height until we had sunk to around 500 feet. By this time we should have placed ourselves at the diagonal point of the square opposite to our take-off point. This done, a turn down wind was made to arrive at the bottom of the field at around 300 feet, then making a turn across wind and lining up for our final turn into wind and the landing approach.

On this my twentieth flight, I had completed the square circuit satisfactorily and made my final turn into wind. It was now a case of increasing speed to around 50 knots for the prevailing wind (more on windy days), and aiming the glider at an imaginary touch-down point on the field. If the nose goes above this point it indicates that you will overshoot, while if the imaginary point rises above the nose it indicates an undershoot. If you want to increase your rate of descent you ease open the spoilers and on the T-21 ease back on the stick as the action of opening the spoilers tends to depress the nose. If you are undershooting you leave the spoilers alone and increase your speed to cover more ground.

On this occasion I had it about right and the ground was coming up slowly and the speed more or less steady. The object was then to ease the nose up as the ground approached and let the glider float along just above the grass, holding it off until it sank onto the ground. This part of the landing is termed the 'round out'. I rounded out at about twenty feet above the ground instead of two feet, stalled and dropped George and myself with a heavy thud onto the grass. Pains shot up my spine and down my arms and the wings vibrated like a fiddler's elbow.

Blissful silence followed as one wing tip slid slowly onto the grass.

**'YOU HAVE CONTROL,' SAID GEORGE**

'All of us,' said George quietly, 'are doomed; but some of us are more doomed than others.'

On the last flight of the day I had really boomed, but subsequent investigation into the bowels of the 'bucket' revealed no structural damage, and I had at least totalled twenty flights without killing myself or my instructor.

At this time, unknown to me, a small committee meeting was held to decide 'what to do about Peter Champion'. What the outcome was I shall never know, but apparently, as I had continued to fly throughout that week, it was thought patience was the order of the day. If I had frightened myself on that first gliding course, I hesitate to think how I had frightened George.

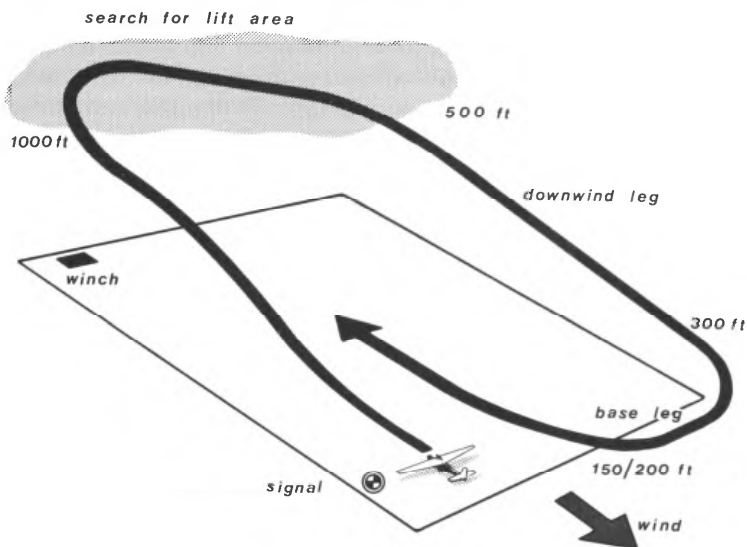

**SQUARE CIRCUIT PATTERN**

---

## Quite happy to fly

---

I managed a further six flights in September and got into my first thermal. It must be remembered that a glider is always descending in the parcel of air that is its immediate environment, and the only way the glider can maintain its height or increase it, is to get into air that is going up at a faster rate than the glider is sinking down. This rising air is called 'lift', and the corresponding sinking air that may be encountered is called 'sink'. The object of all glider flights is to manoeuvre the glider into areas of rising air, and to get clear of sinking air should it be encountered.

There are several ways of basically obtaining lift. One, already mentioned, is hill lift, where the air is blowing more or less against the hill and so lifting the layers of air above and hence the glider. Altitudes are somewhat restricted by this form of lift, and therefore the second form, the thermal, is used when weather conditions permit. 'Thermal' means: heat.

In gliding a thermal implies that a parcel of warm air, comparatively warm, that is, in relation to the surrounding air, will rise above the main air mass, giving 'lift', and that colder surrounding air will rush down to fill the space left by the thermal. This downward rushing air is 'sink'. The thermal, if contacted by the glider will take the glider up, while the sink will quickly increase the glider's rate of descent.

The thermal, however, tends on many occasions to be of a limited diameter and of irregular pattern: also it is invisible. However, it is sometimes indicated by the condensation of the warm rising air

## QUITE HAPPY TO FLY

in the form of cumulus cloud, those white 'cotton-wool' packs seen in the summer sky. The thermal, being the basic shape that it is, which may be estimated roughly to be a rising 'doughnut' in form, necessitates that the glider must be flown in tight circles. This is in order that the glider shall be able to stay in the confines of the thermal. Again, tight circling flight tends to make the glider lose height, but the thermal is going up at a faster rate than the glider is descending: the net result being a gain in altitude.

On a windy day, of course, the glider will drift down wind while climbing in the thermal, which must be vacated by the glider while still near enough to its home field. The glider is then flown back up wind until another thermal is contacted, and the performance repeated.

Gliders flying across country literally fly from thermal to thermal, gaining height, losing a little in the high speed run towards the next, gaining height again and dashing to the next. At the same time the pilot navigates the glider across the land below. This, of course, is for the more experienced pilots and those qualified for such exercises.

In the cockpit is the variometer, which consists of twin thermometer-like tubes in the '21' type of glider. In one tube a red ball rises when in sinking air, and in the other a green ball rises when in rising air. Both tubes are calibrated so that a rise or fall in so many feet per second can be observed.

The exercise is simple.

On an unstable day when there are thermals about the glider is flown off the launch and directly the green ball starts to rise or even the red ball showing less 'sink', the glider is set into a tight turn. This continues, the pilot observing the reading of the vario, which unless the glider is centred in the middle of the thermal, will show erratic readings. The object of the exercise is to get a high steady reading and maintain it until a height has been reached where the thermal has burned itself out. The glider is then straightened out and flown towards where the next thermal is thought to be.

Some thermals, generally on low wind speed days are gentle, while others can be rough, more often on windy days.

It was my luck to connect with a thermal on a windy unstable day, and on this occasion my instructor, Jim, slung the 'bucket' into an eye-ball bending turn that seemed to go on forever. Again I experienced massive disorientation as the circles of green and brown

landscape swept round in front of my eyes, and any idea of where the glider was relative to the ground was lost for me.

'Had enough?' enquired Jim.

I needed no second bidding and nodded quickly. It was to take some time, years, in fact, before I was to get used to the swirling gyrations of thermalling, let alone stay in them or get properly centred.

At this time I had been taught that the less one used the instruments and the more one developed judgement, the better. The easiest way of flying at a constant cruising speed was to line up the horizon with the windscreen and use this as a guide. This was all right, until one day when the visibility was poor and there was no horizon. I flew an instructor named Mike around the sky in a manner he never thought possible for a glider.

Another instructor, named Derek, asked me to make a landing without using the instruments which he suitably blanked off, and he too, discovered my lack of judgement as I rounded out, speeding across the airfield at less than a foot above the ground at a whistling 90 knots . . . 103+ miles per hour.

Apart from erratic flying in relation to speed . . . I always seemed to be bombing along at 70 knots or on the verge of stalling with 'nothing on the clock'. I experienced two main problems. One was a complete disorientation in thermalling, and the other was making a decent landing. I tended to either fly the 'bucket' straight into the ground whereupon I would hear frantic yells of: 'I have control . . . give the bloody thing to me.'

Or else I would round out at twenty feet or so and stall into the ground as I had done with George a few weeks earlier.

It was with little surprise on my part that it came to pass a paradox existed. Lo, and behold, an instructor would regard me with as much premonition of disaster as I regarded the whole concept of gliding. In all I flew with eighteen different instructors, whom I must surely have impressed with my 'death-wish' manner of flying the T-21. I can only state that their courage was greater than mine, for at least in my early gyrations ignorance, was for my part, nearly bliss.

September became October, and gradually winter engulfed southern England in general and Firle Beacon in particular. The enthusiasm of the summer cooled with the weather and the numbers of bodies on the flying field started to diminish. The remaining stalwarts would arrive on the field in all manner of clothing to retain the quickly dissipating heat of their bodies, and it seemed at times

## QUITE HAPPY TO FLY

that there was no limit to the number of sweaters, trousers and socks that one could wear, to say nothing of woollen hats and leather helmets, goggles and heavy footwear. Fortunately for me, my re-occurring bouts of fear and tenseness at least served to keep me warm, temporarily, at least.

By the end of the year I had completed some 50-odd flights, and on one of the coldest days I can ever remember was launched in the T-21 with an instructor named Geoff, to soar the ridge in a biting north-easterly wind. I had had up to this time only one flight of 10 minutes duration, while all the rest were in the order of three or four minutes.

On the launch the icy blast of the airflow, contrasting with the soft, welcoming breeze of the summer launches, bit into the skin, nose, mouth and eyes. At the top of the launch a tinkling sound could be heard as the ice broke off from the cable, and the carpet of snow that covered the countryside was indeed a sight to behold.

We flew up and down the ridge in beats of about a quarter of a mile for twenty-five minutes, while I vainly tried to control the beast with some form of expertise. Geoff asked if I had had enough. I badly wanted to exceed half-an-hour in the air, and so we soldiered on until we had clocked 30 minutes and the icy blast of the airflow had numbed our toes and faces. On landing we had recorded 32 minutes. My longest and coldest flight yet.

We had one more ice-cold journey into the void the following day. Again we beat up and down the ridge with the cold air stabbing through the layers of clothing. The snow wetted the faces of the pilots on landing as it came swishing up over the nose of the 'bucket'.

At this time an outbreak of foot-and-mouth disease had been confirmed, and the flying field closed for the remaining winter months. So my instructors were allowed to survive Christmas and January in the knowledge that I would not be there to dive the 'bucket' into the ground, nor to stall it some twenty feet above the snow. It seemed then that I was never to overcome this problem.

On returning to gliding in the February I was asked to practise stalls. This I did with great expertise as I had spent my whole gliding 'life' to date doing nothing but stalls and dives, and passed the exercise with flying colours.

In March, David, whose attitude to gliding seemed to be that he was quite happy to fly the glider wherever the glider wanted to take him, had apparently impressed the instructors with whom he flew



that his attitude constituted confidence, crammed in a large number of flights, and it was decided that he should solo in the 'Tutor'.

The four shillings he was to be charged for the flight led him to describe the forthcoming experience as one of the cheapest 'rent-a-thrills' he could think of. His trim military moustache bristled nervously as he was levered into the cockpit, an operation which entailed about as much difficulty as getting a thick slice of toast into a small envelope. It was still cold, and David was dressed in cold weather survival gear complete with woollen *hats* and a leather helmet. By the time he had fixed his flying goggles into position the only visible protrusion was his bristling moustache, still twitching and making him resemble a giant rodent about to spring into action.

The controls and performance of the 'Tutor' were explained to him, there being some variance compared with the 'bucket'. I saw him nod, and the towing cable was quickly attached. His launch was in a southerly direction, virtually from the ridge in the direction of Newhaven. The wind was light and the cloud cover high, and I think it was around mid-day.

For weeks David had been wishing he could solo. But there is a saying that when the gods wish to punish us they grant us our wishes. I handed the retrieve tractor to someone else, and with the others clustered around the 'Tutor' to watch David's attempt at his first solo.

In fairness to David, it must be stated he had a rather 'rocket-assisted-take-off' in the form of a snatched launch that pulled him into the sky with great suddenness and speed. As the orange coffin tore skywards with the airflow whistling like a bomb in the struts and wires, great shouts went up behind him of: 'Release . . . abandon the launch.'

But David would have none of this. He tore on upwards as we all waited for the weak link in the cable to break and prevent any further strain on the aircraft. But that too, refused to break, and so the 'Tutor' sped skywards at something in excess of 70 knots (the maximum on the placard read 59 knots). We all waited for the wings to come off.

The wings, like the weak link, also refused to break, but David did not release, even at the top of the launch. The cable, back-releasing by its designed safety mechanism, suddenly freed the tiny glider, which bouyantly shot upwards a further 50 feet or so.

He kept a straight course for what seemed ages, flying steadily

on towards Newhaven, getting smaller and smaller. I could see by the expressions on the faces of the instructors that there was sore concern in the camp. The drill for a first solo is a straightforward square circuit and little else, followed by two more flights demonstrating left and right hand turns and one complete 360-degree turn.

He finally turned back, and it appeared immediately that he was getting somewhat mixed up as the glider yawed from side to side. Eventually it was dropping a wing, which David would over-correct, merely succeeding in dropping the other. Then the nose started to rise and then drop in a screaming dive followed by every type of wild gyration more associated with my flying than David's.

A friend of David's came on the field at that moment, and asked me if David was flying the 'Tutor'.

'I am sorry to say,' I said slowly, 'that I rather think the "Tutor" is flying him.'

As the tiny single-seater careered around the sky, making 180-degree turns this way and then that, someone else called out: 'Quick . . . get out the glue.'

Still at some 700 feet he had arrived over the launch point and began frantically flying up and down the ridge making skidding over-ruddered turns. It dawned on me that he had lost the field. This might sound impossible to the uninitiated, but it is very easy to do. You search frantically for the familiar shape of the field while all the time it is directly underneath you and out of sight.

In cruising up and down the ridge with no north-easterly wind to keep him up, David lost height rapidly and the southerly wind bore him down into the turbulent air out in the valley.

He suddenly sighted the field and turned towards it, but the 'Tutor' is noted for its lack of penetrating any but the mildest of breezes and he was losing height at such a rate that making the crest of the hill, let alone the landing field, seemed well nigh impossible.

The remedies for this problem are two in number. One, is to admit defeat and land out in the valley, choosing another field altogether, and two, to put the stick forward and gain a lot of speed, possibly going down under the ridge, and relying on the speed to be sufficient to enable you to pull up over the ridge and into the field. David chose the latter, and it appeared to be about the only decision of the whole flight. He disappeared from view in a screaming dive only to re-appear seconds later over the ridge, but all too slow. He was not going to make the field.

The 'Tutor', only just over the ridge seemed to stand still in the air, and only at the last second did David push the stick forward, getting the nose down, to alight somewhat unceremoniously in a large gorse bush, his moustache still bristling and twitching.

He removed his headgear to show an ashen face and perspiration streaming down his temples. He was an altogether very frightened man, having allowed sound instruction to be replaced by panic.

About a week later, Rhona, like David, having completed about 70 training flights in the 'bucket' was ushered into the 'Tutor' for her first solo. David, now back on the T-21 for 'further instruction', as the Brass put it, leaned against the 'bucket', with me at his side, to 'watch the fun'. Rhona was scared to death at the thought of soloing, but she was cajoled into it by many words of comfort and helping hands, including those of her boy friend. Had they been married, I would have viewed this with some suspicion, as it seemed a very convenient way of getting rid of the poor old 'Missus'. Anyway, they all had faith in Rhona, except Rhona herself, of course.

If she had learned little else in her training she did have impressed on her mind the dangers of slow flying with the resultant possibilities of stalling and spinning. She decided therefore, that to fly fast was to fly safely; a sentiment not to be taken literally. . . .

She was launched into space, but did not pull back sufficiently for a good steep climb. The result of this is that the winch speeds up and the launch becomes fairly flat and extremely fast, with only a poor gain in height. She reached some 500 feet, pulled the release and turned left, still bombing along at around 60 knots. Next she turned left again, down wind, completed a further left turn across wind, the 'Tutor' making a hideous banshee wail at the high speed treatment. She then made her final turn into wind. There followed an even higher speed on the approach and the orange coffin shot past us and out of sight down the field, coming to rest a few hundred feet from the winch.

Her instructor said: 'It was not the best first solo I have ever seen, nor was it the worst, but it certainly was the bloody fastest. . . .' She made her two following solo flights, which could be described in best 'Farnborough' idiom, 'a couple of high-speed runs over the black sheds!'

Rhona, however was nearly as scared of flying as I was at the time, but she had a steely persistence and gradually built up her courage and skill. However, as already mentioned, flying, can, when

## QUITE HAPPY TO FLY

you least expect it, give you a hearty kick in the rear sector. Rhona's hearty kick came on a day when the wind sprung up while she was flying. As she approached, flying over one of the fences, she was too slow, and the 'Tutor', forgiving old bus that it was, like an old-aged pensioner, just could not penetrate against the wind.

Again, two possibilities exist under such conditions; one is that you select a closer field than the one you had intended landing in. The other is to dive the aircraft at the fence, and with your extra speed pull up over it. Rhona chose neither remedy and soldiered slowly on into the fence with a resounding crash, as she smacked the orange coffin into one of the fence posts. It was the only one that happened to be made of concrete (the others were merely wooden . . .) and sat there crying with the nose of the 'Tutor' in sawdust and her legs sticking straight out of the wreckage in front of her.

'Olé . . . shouted one exuberant member.

She was duly extricated and injected with brandy, poured straight down the throat, and given a couple of cigarettes. The 'Tutor' took a little longer to put back into shape, but Rhona did a week or two on the K-13 2-seat trainer and managed to convert to the 'Swallow', a markedly higher performance single-seater.

She still flies today, albeit more competently, from Lasham.

---

## ‘It’s all yours!’

---

After fifty-eight flights I *did* an Eliza Dolittle from *My Fair Lady*, inasmuch that I pulled off my first near perfect landing without either tending to fly into the ground or round out on the nearest cloud. To prove it was no fluke, I completed two more to great shouts from those on the ground of: ‘He’s got it . . . by George, I do believe he’s got it.’ And ‘got it’ I had. Through some mystery I shall never solve I continued to ‘have it’; the transformation due merely, I suppose, to the patience of my instructors and dogged practice, with more than a little help from ‘above’.

I was immediately advanced on to ‘spins’, that awe-inspiring word that sends slivers of cold ice crystals down the backs of the uninitiated. I was merely frightened of being frightened. My long hard grind and slow progress had constituted a series of difficult hurdles for me, and this new one—‘spins’—seemed bigger than the rest, due largely to the many cock-and-bull yarns ‘spun’ about the subject, many of which are inaccurate. Other stories are told by pilots wishing to impress those less experienced.

The experience of a spin for the first time can be somewhat nerve shattering, and just prior to my first efforts I witnessed a rather humorous episode that could have turned out a little nasty. A young lady, whom I shall name as Carol, had reached a similar stage in her training as myself, and she was told that the next flight would constitute spin practice. She was duly briefed about what and what not to do, and in a somewhat nervous state set off for the experience in the ‘bucket’ with her instructor.

‘IT’S ALL YOURS!’

It is the practice for the instructor to demonstrate the first spin and recovery and get the pupil to try and execute the second. Now the ‘bucket’, as you know by now, has side-by-side seating, and when the instructor pulled up the nose of the ‘21’ in flight, let the speed fall off and kicked on a boot-full of rudder, the ‘bucket’ not unnaturally fell into a spin as desired. However, it was not, as it seemed, desired by Carol, who screamed: ‘No . . . no . . . stop it . . . I don’t like it. . . .’

While the ‘bucket’ rotated in a slow spin, she added action to her words by throwing her arms around the instructor’s neck and burying her face in his shoulder.

Half strangled and partially blinded by Carol, the stout fellow used all his strength and imagination in getting the glider and himself and Carol out of their predicament. This is possibly why many instructors prefer tandem two-seaters where the pupil sits in front of the instructor, out of ‘throttling’ and ‘blinding’ range.

I had the spin and its characteristics explained to me as follows. There were two stages, it seems, the full rotating spin and the ‘incipient’ variety. The latter is the one where a recovery can be made before the spin becomes fully developed. I had already executed one of these, and was now set for the full rotating, eye-ball banging experience.

We took off in the ‘bucket’, and I hoped against hope for a lousy launch to around 600 feet where the practice would not be ‘on’, but we soared in a gentle arc to 1,000 feet, so I consciously forced myself to relax as much as I could.

The instructor jabbered away quietly at my side.

‘The spin is a stalled and yawed condition of flight, to put it simply, so we get into it by stalling the aircraft and applying rudder, and, if necessary, apply a little opposite aileron to fully yaw the glider and make sure one wing drops. We will then fall nicely into the spin.’

‘Yes, I see,’ I gulped.

‘For spinning practice, we make sure we are clear of all other gliders and are flying into wind. We then decide which way we are going to spin: to the left or to the right. Which one shall we try first?’ he asked.

‘The left,’ I said, without any foundation for my choice, apart from that of being left-handed.

‘A good look out,’ he said twisting his head this way and that, ‘and pull back on the stick. . . .’

## GLIDER PILOT

The nose of the 'bucket' rose . . . the horizon disappeared under it, and the airflow went quiet. The controls became sloppy, and as I heard the pre-stall buffet from behind I knew we had reached the summit and the point of stall.

'We now kick on a little left rudder,' he added, 'and give a bit of stick to the right, to provide more drag on that left wing and help it stall before the right . . . and here we go. . . .'

I felt the T-21 twist its fuselage in the yaw provided by the rudder and looking out saw the left wing drop, and the patchwork of scenery begin to revolve as we started to rotate. I felt tense but not as scared as I had thought I would be.

The instructor tapped the airspeed indicator.

'Look at the A.S.I.,' he said. 'Notice that although we are spinning the speed has dropped to about 25 knots.'

I also noticed the altimeter unwinding as we came down like a bathtub full of cement.

At last he said the words I wanted to hear: 'Now the recovery is executed by applying full opposite rudder, in this case right rudder . . . a pause . . . and we then put the stick progressively forward like this . . . and you will see that we are un-yawing and unstalling the glider . . . centralising the rudder when the rotation stops.'

By what seemed to me a miracle the rotation stopped and the nose began to rise, as he eased back the stick.

'Don't forget,' he added, 'that after the rotation stops you centralise your rudder or you may spin the other way. And *ease* out of the dive . . . don't pull the wings off in your haste to recover from the dive.'

We were cruising now and too low to try another spin, but we took another flight, and it was my turn. I got the beast to get into the spin and managed to get her out again, but was a little hasty in pulling out of the resultant dive and pulled a few 'g' on the accelerometer. I tried more flights and more spins, and although I can never lay claim to enjoying the sensation I did manage to cope and cope well.

We then did a series of spiral dives, which can sometimes be confused with a spin, but the airspeed is higher and the controls function in their normal manner. For a few weeks I carried on with spins to the left . . . spins to the right . . . stalls . . . high rate turns . . . and more and more landing practice.

By the beginning of July, nearly a year since I had started, I had logged 78 flights and was still nowhere near solo, it seemed. I then had to practise cable breaks and carry out the expected recovery

## 'IT'S ALL YOURS!'

action. On the launch the cable which is towing you up can break at any height. It can be that the weak link breaks from pulling back into the climb too quickly, or just through fair wear and tear on the cable. Whatever the cause, you can get a cable break as often as four times in four launches, and again you may not experience one for fifty launches. On each launch, however, it must be assumed that you will get a break and have a plan of action worked out for its eventuality.

Cable breaks can be considered split into three possibilities, for the sake of simplicity. Firstly, there is the low break, where you simply lower the nose and land straight ahead. Secondly, you have the high break where you merely complete a rather tighter circuit than usual. Thirdly, and lastly, we come to the medium break, say around 300 feet, where you are too high to go straight ahead and too low to get round in a circuit. This can be the tricky one.

In the medium height and high breaks the nose of the glider is about 45 degrees up. In that position when the power suddenly fades or the cable breaks the glider is left in a nose-up attitude, and the speed will rapidly fall off and the glider will stall, or may spin at low altitude if left to its own devices. The action required, therefore, is to get the nose down quickly to the approach speed and see whether or not you can get in ahead. If not, you must decide whether you have enough height to go round in a tight circuit, and failing this, turn off to one side and snake back into the field in an 'S' turn, ensuring that as you come out of the 'S' you are facing into wind and into the field.

The method for practising cable breaks is simple: as you are climbing steeply the instructor will suddenly pull the yellow release knob. There is a bang as the cable comes off and it's all yours.

My first practice came unsuspectingly while flying with an instructor, who, though while quite efficient, was fairly new to instructing. We climbed lazily into the sky and all was sweetness and light one second, and then . . . bang. . . . As the old Bovril advertisement used to say:

### *Prevents that sinking feeling*

Only the cable break promotes that sinking feeling, and I quickly lowered the nose only to 'freeze' mentally as we gaily flew along towards the winch at a mere 300 feet. We used up the available field



and got closer to the winch with me not turning or doing anything constructive.

'Well, say something,' said the irate instructor, 'even if its only "goodbye".' . . . He took control, and somehow or other got us safely down.

Cable breaks, like everything else in gliding require practice. Like other gliding and flying phenomena they are not dangerous if you know what to do and do it promptly and calmly.

Thermalling practice followed. The disagreeable disorientation I experienced continued, and I found I was leaving thermals voluntarily more often than I was attempting to stay in them. The disorientation was merely brought about by tenseness and being too nervous, and again practice and yet more practice was needed.

With 84 flights now logged there was still no talk of my going solo. I knew of one extreme case of a pilot making 500 instructional flights and *never* going solo; and I knew of one or two that had taken 140 dual flights before being let loose on their own. However, most seemed to get there in about 60 to 70, and despondency was settling on me.

In retrospect, this was not a bad thing really, as the more experience you can stuff under your belt before solo status the better. There is no substitute for experience, as indeed one of our members showed who had soloed after only 40 instructional flights. He misjudged a landing rather badly in the 'Tutor', and in the heavy bouncing that followed pushed his backside through the bottom of the glider. His head disappeared from sight in the cockpit as he roared past, giving the impression that the glider was flying under remote control, which in one respect, I suppose it was.

It is not, of course, the intention of this book to create the impression that gliding is the 'hairy' pastime that some of these incidents might infer. They are, largely, the exceptions to the rules.

With my own flying I still seemed unable to get the necessary confidence. What with my own failings and, surely, the way I must have put the 'wind up' some of the instructors, it was to take a little while.

Mercifully, at this stage I flew with an instructor named Chris. Chris was, and still is, one of those rare mortals who have an utter zest for life in general and flying in particular. He is fortunate in having a wife with a wonderfully similar disposition. He is also a pilot second to none in flying ability. He can sniff out thermals in

## 'IT'S ALL YOURS!'

the most unlikely places and still be airborne when all others are firmly placed on the ground.

I am sure to this day that Chris is one of those 'half-man and half-glider' creatures descended from a long line of albatross. He was for the moment completely integrated with whatever glider he flew and so experienced that he could extricate the glider and its occupants in whatever unfortunate position they might be placed by the pupil. Hence, he would allow the pupil greater range in his activities, and the pupil would learn more at a far greater pace.

When flying with him he told me I had complete command of the aircraft, and it was up to me to get it up, fly it round and get it back. If I misjudged and had to land out in another field, that, he told me was my problem, and he was only along for the ride. When I failed to put myself and the glider in any predicament he would take over and place us in a corker, and then tell me to extricate us from it; sometimes we found ourselves too low on the approach . . . sometimes there was a cable break . . . too high on the circuit . . . skidding and slipping turns . . . sudden spins and stalls . . . and so on.

A few weekends of this, and then six flights in one day with an instructor (like me, named Peter) ensured that the magical first solo was not far away. On the last flight of that day of the July course I launched with Peter, only to get a real cable break at around 350 feet. I turned out to snake back from the 'S' turn, only to find that the noise of the cable breaking had stampeded the cattle and sheep beneath us. As I turned across wind, so they turned too, running beneath me and parallel with the track of the glider. I eventually had to turn down wind and they also turned in the same direction. I banged on more speed, as down wind landings are both tricky and undesirable, and sank into a mass of sheep and cattle.

By some chance we happened to land in a space between the animals and Peter said:

'Very good . . . there was little else you could have done. Fancy going solo?'

---

## A three-minute period in one's life

---

On the Monday of that July course I had been offered the magic of my first solo in the 'Tutor'. . . . I had declined.

This was unheard of and again the mutterings of 'coward' could be heard. However, the question of my courage was not the deciding factor. I had flown six flights that day; it was late evening: I was cold, tired and hungry and felt that the sum of these conditions indicated that I would not be giving myself the best advantage in going solo on this day. I had logged 89 flights. Altogether they had shaken up my nerve fibres, had involved countless hours and gallons of sweat on the field for nearly a year, and, I reasoned, if I were to solo I would at least give myself every possible advantage.

'I don't think I slept much that night, and the following day I stayed at home watching the torrential rain pour down the windows from the low black overcast. The day was spent in thinking about that first solo, and perhaps whether I should have taken the opportunity when it occurred. Still, one must make one's decisions and abide by them. Wednesday was a day pregnant with silence. One of those rare days when there is absolutely no wind, reasonably warm and high overcast. It is a day sent by the gods for pilots making their first solos and I felt that the 'Powers that Be', had looked down and said: 'Well, here are the perfect conditions for your first solo . . . what are you going to do about it?'

I arrived on the field at about 9.30 a.m., a little late, but it had taken me the preceding hours to summon up enough singleness of purpose to decide to go at all. Once again I was met by surprised expressions

and grabbed by Chris for three check flights in the 'bucket'.

It was a wonderfully calm day, and I flew all three circuits quite well, ironically enough on the same run between Bo-Peep Hill and the Beacon, as I had flown on my very first glider flight nearly a year before. When we landed after the third flight in the 'bucket' the 'Tutor' was ominously lined up, and as I vacated the cockpit of the T-21 I was surrounded by enthusiastic members, making escape impossible. I managed to claw my way through them, and spent a much-needed nervous 'penny' behind the gorse bushes to collect my wits somewhat.

As I stood there I reasoned that like the 'condemned man' I had eaten a hearty breakfast. I could see it was a dead calm day with no wind, no thermals and no turbulence, and that conditions could never be more favourable.

Of course, I did not *have* to go. But to relinquish the opportunity now would mean the end of real gliding, as I should be left on the '21' and justifiably receive no interest from instructors, who would feel that any further instruction was quite futile.

Neither did it seem sensible to assume that the instructors merely wanted to kill me off and have the 'Tutor' smashed to matchwood in the process. They might not mind so much about killing me off, but to damage one of their precious gliders intentionally would be completely out of character. The self-imposed 'confidence trick' took all of three seconds, and I zipped up my trousers and emerged from the bushes walking quickly towards the orange coffin. The devils had the cable ready and someone was holding the wing up. The shoulder straps hung lazily over the cockpit sides and the total silence was unbearable.

Chris was standing by the nose of the 'Tutor' grinning from ear to ear in the instructor's characteristic pose for such events. The other less diplomatic members clustered around and levered me into the tiny confines of the narrow cockpit. Still no parachute even on this machine: but I suppose I was still at the 'expendable' stage.

I was hastily imprisoned in the 'Tutor' as eager hands did up my straps and pulled them tight. I completed the cockpit checks. The instrumentation was certainly not 'London Hilton', and Chris ran over the variations that existed between this machine and the 'bucket'. The astounding thing was the stick. It already seemed to have broom-handle proportions, but once seated in the cockpit it felt as if the thing would poke up one's nose if one attempted to pull

it back. As the sides of the cockpit pressed against my shoulders I dared not breathe too deeply lest the whole horrible bag of tricks fell apart.

Chris asked me if I were happy over the details he had given me, and I said that I was not and asked him to repeat it all over again. He knelt down with a hand on my shoulder, and I tried to remember his words through the mental block that seemed to be cutting off my brain.

'Your speed on the climb should be about 45 knots,' he said slowly. 'Signal by wagging your tail to the winch driver if it is too fast. Cruise at 35 knots, or 40 if you feel happier, and use about 45 knots on the landing approach. Just fly a normal square circuit and don't try and do too much. Any problems?'

'I'll let you know when I get back,' I replied.

He picked up the cable and I told him to hook it on and let's get on with it.

The nose of the glider was shorter and shallower than the protective snout of the 'bucket' and the tiny windscreen more decorative than effective.

I heard the instructions given to the tractor driver to tell the winch driver that this was a first solo and to give an even steady launch. The 'bodies' crowding around my cockpit dispersed with great smiles and jocular advice such as: 'If you get lost, you can always ask a seagull the way back.' Then one young pilot handed me an empty bottle with the remark: 'Don't be alone up there . . . have a Coke.' I advised him what to do with the bottle and took a deep breath, forcing my shoulders against the sides of the cockpit. The winch was ready.

The wing man was holding up the wing tip, and I shouted: 'All clear above and behind?'

'All clear,' shouted Chris.

'Take up slack,' I shouted, raising one finger.

The bats waved and the winch revved its engine while the cable went taut and rocked the nose of the 'Tutor'.

My heartbeats rose into my throat and I raised the other finger.

'All out . . . all out.'

A pause.

The 'Tutor' suddenly lurched forward, and I was snatched into the air. I glanced out half expecting to see the wing man still hanging on to the tip, but I was alone and the air had gone cold hitting my

### A THREE-MINUTE PERIOD IN ONE'S LIFE

face as it buffeted across the silly little windscreen.

I was at about twenty feet above the ground and the wretched glider was already yawing away from the winch. I put this right with a bootful of rudder and aileron. I could see that the hills were dropping away into the valley . . . my speed increased to 45 knots and the ground slunk away some 100 feet below as I eased back the 'broom handle' and settled into about a forty degree climb.

The 'Tutor' made the pilot feel more exposed than did the '21'. I felt all 'head' and little 'glider' as the orange coffin bounced its way up, arching over the beacon and the winch as the altitude increased from 300 to 500 feet. The speed had shot up to 60 knots, and for some inane reason I forgot to signal the winch and reached the top of the climb at 650 feet with the air screaming in the struts and wires. With a frantic shove on the stick I dipped the nose and pulled the yellow wooden knob twice. The 'Tutor', free of its burdening cable shot up another 50 feet and I levelled off and throttled back to just under 40 knots.

Sudden tranquility was coupled with the tense strangeness of an unfamiliar aircraft and wondering thoughts of whether I could fly the thing properly or not. I commenced a shallow right turn out into the valley and the airflow sung in the wires like a distant steaming kettle. As I flew along the crest of the downs I was impressed with the stillness of the day and the high clouds in the distance over Eastbourne.

The 'Tutor' ate up the distance and the altimeter slowly unwound as I was jerked back into reality of lining up my landing run and judging my cross-wind turn and final turn. I flew on over the chalk pit and the hangar at the top of Bo-Peep hill and turned cross wind over the fields below, carefully picking my final turn and lining myself up for the landing approach. I was a little high and I increased speed to 45 knots and opened the spoilers gently.

The grass came evenly upwards and I slowly rounded out and sped across the ground no more than six inches from it. The 'Tutor' lost speed and the mainwheel touched, slowing me up before coming to a gently rocking halt and one wing dropping lightly onto the grass.

I undid my straps and leaned my head back against the leather headrest, taking in a steady deep lungful of air, positively revelling in my first solo experience and 93rd flight.

Little figures ran from the launch point to where I had landed and

## GLIDER PILOT

swiftly pumped my hand up and down in congratulatory bursts. I was wheeled back and set up for my second and third solo flights to complete the left and right hand turns and 360 degree circles.

I remember little about solos 'two' and 'three', except that I managed to get 700 and 750 feet launches. This is because the emotional experience of that first solo is imbedded in the memory and can be recalled on a mental screen like an old home movie. It is in reality only a part of one's training, yet it is also a three-minute period in one's life that makes all the foregoing hard work and strain infinitely rewarding. Thrown on your own resources you cope without too much difficulty, and yet the feeling of such an achievement is beyond description. When I received my gliding certificate signed by Prince Philip, President of the Royal Aero Club, and noticed it was Number 51689, the fact that there had been 51,688 before me did not in any way diminish my satisfaction.

It had taken me six hours and twenty-one minutes of dual instruction and 92 flights to go solo, and now it all seemed worth it.

That evening, after a further solo during the day and a final T-21 flight just for fun, I bought the drinks in the public house and felt that at last I had arrived. I was a solo pilot and all of my troubles were over.

As I was now a pilot I should have known better than to think like that. But no matter, flying has its own ways of reminding the erring and I was to be no exception.

---

## Flying is full of characters

---

For the rest of the summer I greedily logged as many 'Tutor' flights as I could, with the 'Tutor' frightening the life out of me on some occasions. Sheer thoughtlessness and lack of planning led me into difficulties, all of which were of my own making.

Firstly, I had become used to flying circuits, and had begun to judge them rather well, so that I was not allowing any margin for error. On one particular day I was flying down wind and getting very low. The simple remedy is to turn in and land early, which would have merely placed me further up the field and a little way from the take-off-and-landing area.

I had, however, become a creature of habit and was determined to reach the bottom of the field for my turn across wind. I did reach the end of the field, but all too low. I continued across wind and started my final turn only to see to my horror the white lines of daisies speed past my right wing tip, which was by now no more than inches from the ground. I straightened up and was down almost immediately. George wandered across the field, and in his own quiet inimitable manner made it quite clear what he thought of such flying.

A week later I was caught out again. The winch started to lose power when I was pulling back into the climb, and as the speed fell off I lowered the nose of the glider still flying towards the ailing winch and hoping that it would pick up.

It didn't.

I arrived over the winch and the hangar on the hill at only 400 feet,



## GLIDER PILOT

abandoning the cable and commencing a turn that revealed the field below me was covered with white dots. The dots were Sunday strollers staring up at the glider and waving: completely oblivious, it seemed, that I was making an emergency landing and liable to land among them.

Hadn't they seen the warning notices on the field?

I was too busy to worry unduly as the height was slipping away, and it seemed miles to go before I should be able to whip the 'Tutor' round in the turn and get back into wind with enough field left for a landing.

Again the daisies whipped past my lower wing tip, and I was nearly round into wind when the wretched tip touched the ground as I kicked on opposite rudder and aileron to prevent myself from ground looping. The orange coffin bounced to a halt with canvas flapping from a jagged hole in the wing and the Sunday strollers uncomfortably close. I patched up the wing, made two more flights to recover what little confidence I had left, and called it a day.

If flying was 'biting' me occasionally, so it was biting others.

I arrived on the field one morning horrified to see the old T-21 in about a hundred pieces stacked up in the hangar. The previous day an early solo pilot had been making his third or fourth solo flight in a rather high wind, and on looking down at the ground on his down-wind leg noticed that the *ground* speed was extremely high. This is of little consequence to the pilot, as it is the *airspeed*, governed by the airflow over the glider, which is important, and it is that speed which appears on the airspeed indicator. For example, if you are flying at 40 knots airspeed, down wind in a 20 knot wind, then your *groundspeed* is 60 knots. If you are flying at 40 knots *airspeed into* a 20-knot wind, then your *Groundspeed* would only be 20 knots (the speed being controlled by the stick).

Unnerved by the high ground speed and approaching his cross-wind turn, he pulled back on the stick to lessen the apparent 'speed', and in so doing lowered the airspeed to that of the stall. To make matters worse he started to turn at the same time, and being a little low now, made the turn shallow with insufficient bank, trying to get round by using a lot of rudder . . . these, of course, being the ingredients for the spin . . . and though it was obvious to the horrified spectators on the ground, to his surprise he spun into the ground and wrecked the glider.

Fortunately, and miraculously, he came out of the splinters and

## FLYING IS FULL OF CHARACTERS

dust unscathed. Unfortunately, it cured him of gliding.

A similar result was obtained at this time by a very experienced pilot who was trying to find lift over the hill on a ridge soaring day, but he got down to 400 feet when most pilots would have turned for home. He persisted in 'scratching' for lift on the hill and duly found it. I was watching this, and saw him suddenly pull back on the stick in the turn to tighten it and in doing so reduce his speed and spin off.

The glider, a high-performance machine with less forgiving characteristics than most, spun steeply and straight down. As it disappeared from view there was a dull ominous thud. Tractors and cars raced up to the crest of the hill searching for the remains of pilot and glider. The only evidence of the impact was a deep furrow torn in the grass and happily and surprisingly we saw that the glider had landed safely in a field in the valley.

It transpired that in trying desperately to recover from the spin he had managed to pull out but clipped the side of the hill with his wing, the impact throwing the glider towards the valley, where he had recovered control and landed. It was determined afterwards that had he hit the hill six feet further in he would have undoubtedly written off both himself and the glider.

Dangerous? . . . Yes, but again pilot error.

My personal worries were now minor by comparison. I just could not get the 'Tutor' to stay up. Not that it wouldn't of course, but I could not find the lift, and when I did I could not stay in it and spent the rest of the year flogging myself to death recording no more than four-minute circuits. Any despondency was lifted by many other incidents that occurred at this time, including the introduction to the club of Felix, the 'Phantom Flier'.

Felix was a tall handsome extrovert who had returned to gliding after many years absence. He was now in his more mature forties, a circumstance belied by a boyish enthusiasm and devilishness that seemed the basis of the many 'incidents' in which he became almost continually involved.

He had complete confidence in himself and flew the T-21, the 'Tutor', K-13, 'Swallow' and 'Olympia' all within one year of joining the club.

An extrovert does not, however, make many friends, in that most of us prefer to subscribe to the 'herd' instinct and stay lost in a crowd. Felix, by comparison, was quite happy with his self-induced

limelight, and personally I liked him, admired his spirit and believe him to have been a far more careful pilot than he would have had us believe.

Not for Felix the dull routine of circuits and bumps in unsoarable weather. He would liven up the day by landing in another field in and out of the hay ricks, or by shooting up the field in a fast landing, explaining that he pulled the cable release in mistake for the air-brakes lever.

On another occasion Felix and myself found a sheep on its back in the flying field with its feet pointing straight up in the air. After much prodding and pushing the unfortunate creature rolled over on one side with its feet still sticking rigidly out. It was stone dead we concluded. By now surrounded by other club members we decided that it should at least have a 'Christian' burial of sorts, and detailed a thin pimply youth to go off and inform the farmer. A spade was produced from the depths of the hangar and a sizeable trench dug for it.

Three members came across the field and told us that the grave was duly dug and ready for its occupant, while the remainder began to tug the dead sheep making an ungainly, heaving and perspiring funeral procession. 'Christ', shouted someone, and we saw the sheep suddenly struggle from the grasp of the burial party, kick out its feet and go shooting off down the field.

The pimply youth who had informed the farmer of the sheep's demise returned as it made its retreat from view.

'I've told the farmer the sheep is dead and that we've buried it.'

'Well it isn't,' said Felix, 'and we haven't.'

'You had better go back and tell him it's all right,' I suggested.

'Don't bother,' grinned Felix, 'wait until he comes up to count them. It'll take him all day to work out why he now thinks he's got one too many.'

'I'd better fill in the grave,' I volunteered.

'Shouldn't bother,' said Felix, 'the way you "Tutor" people fly I expect one of you will need it.'

Unfortunately, Felix's prowess as a pilot led him into a few bouts of drinking at a nearby inn. This was quite acceptable in the evenings after flying had stopped, but somewhat disconcerting when it began to become a lunchtime expedition with one or two others.

The climax came when one afternoon Felix returned somewhat tanked up from the lunchtime excursion and climbed gaily into an

available glider already lined up for launching. 'Give ush a cable,' burred Felix, and the pimply youth who had had the job of informing the farmer of the sheep's demise nervously obeyed the command.

A tall instructor ventured onto the scene and after approaching Felix, whose bleary eyes beneath the cockpit canopy made him resemble a goldfish in a bowl, put his foot down on the cable and kicked it to back release it from the towing hook. Felix was furious and released the canopy making wild gestures to the instructor who leaned down, looked him straight in the eyes and said firmly: 'Your prowess as a drinker exceeds your prowess as a pilot . . . get out!'

Felix duly got out, stomped off the field never to return as a flying member again. This was in some ways a pity, in others, a blessing.

In colourful contrast to Felix was an instructor who became dubbed 'Apollo', as he appeared dressed more for the moon-rocket programme than for gliding. He weighed some fourteen stones, and clad his hulk with every conceivable type of flying equipment he could manage to put on or zip up, including a jet pilot's helmet with flying goggles, vintage 1940, an immaculately pressed, blue, zippered flying suit covering an off-white fisherman's knit polo-necked sweater complete with a pilot's rescue whistle and test pilot's knee pad, onto which the tiniest detail regarding the flight was duly logged.

His bulk was further exaggerated by the fleecy lamb's-wool and leather flying jacket and vast black leather flying boots, size 25!!

What had undoubtedly been a 'fighter pilot's' moustache, had from years of turbulent airflow and screaming dives become somewhat moth-eaten and walrus-like in appearance, and only served to accentuate a receding chin.

He was also the only instructor I have ever known to sport an altimeter in his car which was religiously set at sea level every weekend. I can only suppose he suspected the height of the flying field above sea level might alter in some way.

His favourite dogma, was that a glider should have a heavy landing check on all but the most 'intimate' of landings. As most of mine tended to be more detached than intimate, his time was fully occupied after my landings pulling and shaking hell out of the frail little 'Tutor'. At times I was sure he must fall into a mass of twisting and breaking pieces and be swallowed up in the resulting sawdust never to be seen again. The 'Tutor', however, fought back and

resisted his destructive advances, as puffing like a bull elephant and perspiring freely he would claim the aircraft fit for further flying.

He would use the signal whistle on landing to summon the retrieve crew until one member finally commented: 'All right ref: don't get your goggles in a twist.' Whereupon he was cured of the irritating habit, only to make us endure others, such as his 'flying by numbers', a system whereby he always kicked the rudder bar to its limits and banged the stick over as far as it would go, resulting in sudden spiralling turns and a whole circuit with the pupil feeling vastly exaggerated and uncomfortable.

I recall having one terrible argument with him high over the Sussex downs when he insisted we were in lift going up and I swore that we were in sink coming down. The fact that the altimeter and the variometer bore out my claims, aided by the quickly approaching ground, appeared not to sway his opinion in any way and resulted in the only occasion when I lost my temper in the air. I let go of all the controls and said loudly: 'All right . . . we're going up, so you fly the bloody thing.'

Two minutes later we were back on the ground and this was the last time I flew with 'Apollo', as he was shortly to make his parting from the club. I felt this was inevitable, and it justly coincided with the film *Battle of Britain* hitting the cinema circuits. It happened as follows. One morning 'Apollo' was taking up a new pupil in the 'bucket'. The already nervous pupil had nearly had kittens when confronted with 'Apollo' in his moon mission attire.

As the '21' slid past on the initial part of the launch the other club members sent up great cat-calls of: 'Tack-a-tack-a-tack-a-tack-a-tack . . . beware of the Hun in the sun . . . Angels-One-Five old fruit . . . don't forget your whistle . . . Per Ardour and his Aspidistra (referring to his moustache). . . .' These ribald remarks must have incensed him and put paid to his reign, for he landed from that flight, recorded it on his knee pad and clumped off to his altimetered car never to be seen again. 'Apollo', along with some of the others, certainly constituted a character, but flying is full of characters and I feel would be somewhat worse off without them.

So I ploughed on in the 'Tutor' with occasional check flights in the red and yellow T-21, a replacement for the crashed machine provided through the auspices of frowning insurance underwriters. Although an exactly similar model, this T-21 was a far nicer machine to fly feeling a little more sensitive in control response,

## FLYING IS FULL OF CHARACTERS

or perhaps I was at last flying better.

If flying was teaching me little else it was serving to continue its occasional kick in my rear sections. I went through periods where I would become somewhat complacent in my flying, only to be suddenly and frighteningly reminded that one must stay fully conscious and alert when gliding.

The air is a fickle environment and the 'Tutor' being a light machine, some 500 lbs. against the T-21's 900 lbs., fully loaded, it tended to bounce about in rough weather. I recall making three flights one morning in dead calm air which merely resulted in much needed circuit practice. On the fourth and just off the launch I ran into the most severe turbulence that not only bounced me all around the sky but made any form of definite control seem impossible. As I have mentioned, one cannot get out if one runs into these situations, but must simply sit tight, think out the problem and take cool and calculating decisions to extricate oneself.

One would feel some substantial confidence being strapped in the T-21 in such conditions, but in the lightweight 'Tutor' there was no feeling of being attached to anything. Coupled with the complaining groans and squeaks from the airframe this made for some really 'heart-in-the-throat' flying on occasions.

I spent over a year on the 'Tutor', and was still unable to log anything in excess of four minutes in the air for any single flight. After forty-eight 'Tutor' flights and a series of nice approaches and landings, George told me: 'No more 'Tutor' for you. You'll learn nothing more on that machine. Fly the K-13 in future.'

This was the death knell for solo flying for a time, as the system was that after some 'Tutor' flying one would go on to the German Schleicher AS-K 13, a high-performance tandem two-seater. After an indefinite period of retraining one would then convert to the Slingsby 'Swallow' which although of lower performance than the K-13 was a considerable improvement on the 'Tutor'.

I thought this intermediate training on the K-13 would take a week or two before converting to the 'Swallow'. I was to prove a little 'out' in my calculations. . . .

---

## Conversation with my headless companion

---

Alexander Schleicher's K-13 is a sleek-looking glider constructed of welded steel tubing and a plasticised fabric covering. It is fully instrumented and has dual controls. The wings are swept forward, but the great luxury (apart from parachutes) is the long clear-view cockpit canopy. This not only saves one from the full force of the elements, but provides one of the best all-round views from a glider that I have experienced.

It is, however, not as forgiving of clumsy handling as the T-21 or the 'Tutor'.

Sitting in the front cockpit I was horrified to find on my first launch in this machine that on release from the cable at the top of the climb it possessed no convenient protuberances, such as the 'bucket' or the 'Tutor' had, by which one could line up the machine with the horizon. The horizon did not conveniently cut across the wind-screen, as it had done on the '21', nor was there a convenient Pitot tube with which to do the same thing, as one had enjoyed in the 'Tutor'.

There was also another little lever on the right-hand side of the cockpit with which I was unfamiliar, as neither of the previous machines I had flown sported such refinements. This little lever was the *trim* control.

It operates a little auxiliary flap on the elevators, moving in an opposite direction to them. So when the pilot pulls back on the stick and wishes to maintain this attitude he pulls back on the trim tab. The elevator has come 'up' from the stick movement, and the

## CONVERSATION WITH MY HEADLESS COMPANION

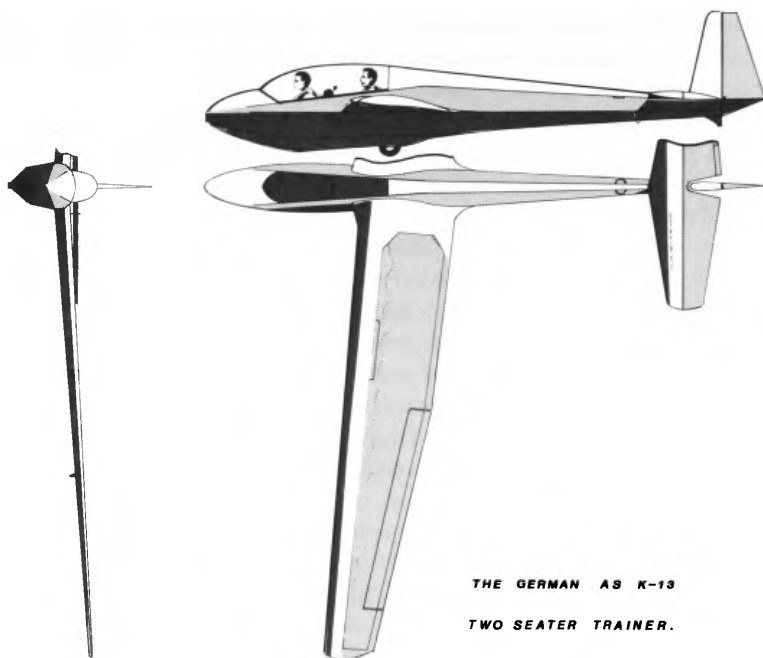

trim tab has gone down, so that the force of the airflow is assisting the stick movement. It is manipulated by feel, and if the pilot puts the stick in a position for level cruising flight he will feel either a backward or forward pressure on the stick which he removes, or 'trims out', with the trim lever. Its advantage is that once an attitude is selected the pilot can fly 'hands off', and the glider will fly at the selected 'trim'.

The trim lever is important for relieving the stress of long periods of cruising. It is also useful for holding a selected landing speed should the pilot's attention be interrupted and he allows the speed to fall off by allowing the stick to come back. One can literally trim out to any desired speed. What with no horizon assistance, and not knowing how to use the trim lever properly, the K-13 cavorted all over the sky, and in a few seconds I was back to my meagre standard of effort in the 'bucket' some two years before.

Added to this the K-13 was aerodynamically superior to the other machines, and when the nose went down the speed built up in a



hurry. This tempts the pupil to pull back nervously to lose the excess speed, only to be frightened further by seeing the wings bend rather abruptly.

I then began to develop a silly habit of looking down the dipped wing in a turn which resulted in me becoming thoroughly disorientated and losing control of the speed in the turns. The high speed fluctuation led to tiring and annoying high 'g' recordings.

After a few flights in my new 'mount' I concluded somewhat rapidly that I could not fly at all. I was snowed under with problems and rather nervous of the high speed reactions of this glider, and it took little time before I loathed the aircraft altogether.

I was nervous and irritated and was literally going through all the training difficulties I had previously experienced. The fact that David had also had one or two frightening flights in the 'K' and had finally packed in gliding altogether was of no further encouragement.

I soldiered on repeating the same mistakes, and could not get used to the fact that the 'K' had more penetration in winds, and that therefore it was necessary to go back a little further behind the fence to commence one's landing approach. I had become so used to turning the 'Tutor' almost over the fence that I continued to do the same with the 'K'. A long series of bad overshoots culminated in my hitting a ridge of high ground that paralysed my back and arms for about five minutes.

Also the 'attitude' was different. After flying any glider one gets used to cruising at a certain visual attitude. With the '21' the attitude is a little nose high by comparison to the 'Tutor', in which most of the time one was increasing speed when losing penetration and the attitude was somewhat lower. But after a year on the orange coffin I flew by habit, and in attempting to copy the same attitude in the 'K' I was continually flying too nose down and hence too fast.

After about 40 flights and nearly a further year's flying in the creation of Alexander Schleicher, I learned how to trim out the machine for normal cruising flight. Still it was an inescapable fact that the 'K' frightened me, and it was in July the following year after nearly three years as a club member, that an instructor named Val told me on landing: 'You are so nervous and strung up in your flying that I can teach you no more, nor will you progress any further until you can rectify the problems.'

It was after this that I went away and sat quietly in the car on the

## CONVERSATION WITH MY HEADLESS COMPANION

top of some convenient hill whenever I got the chance, and over a period of some weeks while I tried to work something out. I wanted to be a glider pilot. Although it appeared to be the last thing I was ever cut out for, up until the time I had come off the 'Tutor' I at least felt that I had accomplished a great deal after my first faltering efforts. Yet now I seemed to have turned full circle and was back to 'square one'.

I felt that I had spent so much effort and nervous energy that I just couldn't give it up, but more than this I could not accept the failure, not even to myself, let alone others, and the irony was that the solution was in my own hands . . . or was it? . . . Was it not more in my own mind?

I began to analyse *fear*.

Fear, I concluded was built into the 'system' in human beings, and like many other commodities programmed into the human form, it comes in varying amounts with different people. In regard to fear, I obviously had been treated to a fairly large helping and would have to find a way of monitoring it when it became a nuisance. Fear, also I reasoned, was there to protect, and so I must beware of the danger of removing all fear. Again fear is triggered by imagination, and I possess a greedy helping of that mental faculty.

From this basis I gradually 'trained' myself, firstly with the basic essentials of having confidence in the glider I was to fly, and secondly confidence in the instructor, regardless of who the next unfortunate might be. They were all good, anyway. Finally, and most important of all at this time, I had to have faith in myself.

I had logged over 200 flights by now and 48 of these solo. Were my flying that bad, I reasoned, I should not have survived the 48 solos, never mind the 150-odd training flights.

I knew I had flown well on occasions, and therefore it was not an impossibility to increase the number of these occasions. I had also managed to contain my fear and emotions in the early days on the '21', and therefore I could do it again. I returned to the conscious briefing I had subjected myself to in those days, and prepared to start again and try and relax, and not try so desperately hard. One can try too hard with flying. . . .

Just prior to this the club had sold the 'Tutor' for some silly figure in the region of £25. The man who gave me my introduction to gliding, 'Pop' Orford, being of advancing years, had said 'good-

bye' to his solo flying, and the whole club was to go through a streamlining in the training system.

Once more I approached the 'K', and on returning from a call of nature from the gorse bushes overheard an instructor who had been detailed to fly in the K-13 ask the duty instructor of the day: 'Tell me . . . has Peter Champion frightened anyone recently?'

The other instructor stood thoughtfully for a few seconds, while I stood rock-still behind the gorse.

'I don't think so old man . . . not for about a year anyway.'

'Oh good . . . good . . . good.'

I emerged from the bushes and smiled at the poor soul detailed to fly with me.

'Morning,' I beamed at him. 'How about some stalls and spins?'

He smiled back weakly. 'I think we'll just fly a couple of circuits and see how you make out,' he said, excusing himself.

This we did, and I found I was flying well, using my system of self-briefing and threatening myself with all kinds of penalties if I let those old 'nerves' get the better of me. The poor instructor was almost hysterically thankful when I finally deposited him on the ground still sound in wind and limb. As he resigned from the club shortly afterwards I must confess to some evil glee at feeling some responsibility for his accelerated departure. I was also beginning to feel some regret over my unintentional Communistic brain-washing procedure, whereby I scared the pants off instructors one minute, only to fly perfectly well the next. I think it was possibly something to do with this when they decided to let me convert to the 'Swallow', my goal for over two years. They let the Devil take the hindmost, which of course, he normally does.

It was a wonder to me why I was never asked to resign and take up boating or rock climbing, and let the rest of the club get on with the function of enjoying their sport. Perhaps after all they too were fascinated to see what I would do next, or too fed up with me to care much either way.

Whatever the cause, after being taken through a long series of spins, stalls and cable brakes in one day, I was asked: 'How would you like to convert to the "Swallow"?'

'Yes,' I nodded with some excitement.

As usual on these occasions, once I got out of the 'K', and found the 'Swallow' all ready lined up for a southerly launch, I found it would necessitate a distinct cross-wind landing sweeping in over

## CONVERSATION WITH MY HEADLESS COMPANION

the Beacon and landing along the ridge. Fortunately, cross-wind landings had been one of the few functions I had taken to naturally and they have never presented me with any problems . . . to date.

As I clipped on the parachute feeling a little less expendable than I had done in the 'Tutor' I clambered eagerly, if nervously, into the 'Swallow' cockpit, reminding myself that I should achieve nothing if I let the old panics and fears invade my thinking. I strapped myself in and had the controls and instruments explained to me, although there was little that was new except the arrangement of the panel instruments.

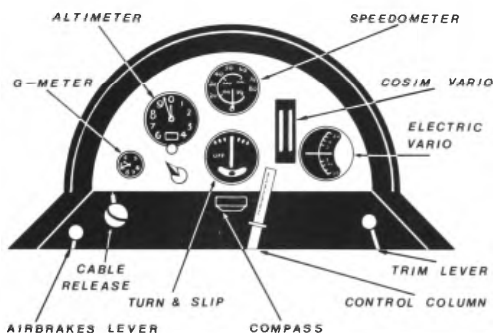

SWALLOW INSTRUMENT PANEL

The canopy was placed over my head and I locked it, having gone through most of the pre-flight checks, save the airbrakes, which I now duly tested and locked. I opened the clear-vision panel and breathed in the warm September air, and once again I realised there was a problem of attitude. The canopy rim seemed very high compared with the 'K', and I reminded myself to remember this when I took off. However, I had waited 233 flights for this moment, and having finally strapped myself into the 'Green Ball Express' I was intent on testing my new found wings.

All was ready, and I signalled 'All Out' only to have a terribly fast snatch launch that whipped me up to 70 knots before I had chance to signal. Added to which I had left the clear-vision panel open, and the noise could only be compared with an express train entering a tunnel. I released at 700 feet and only had time for a quick

## GLIDER PILOT

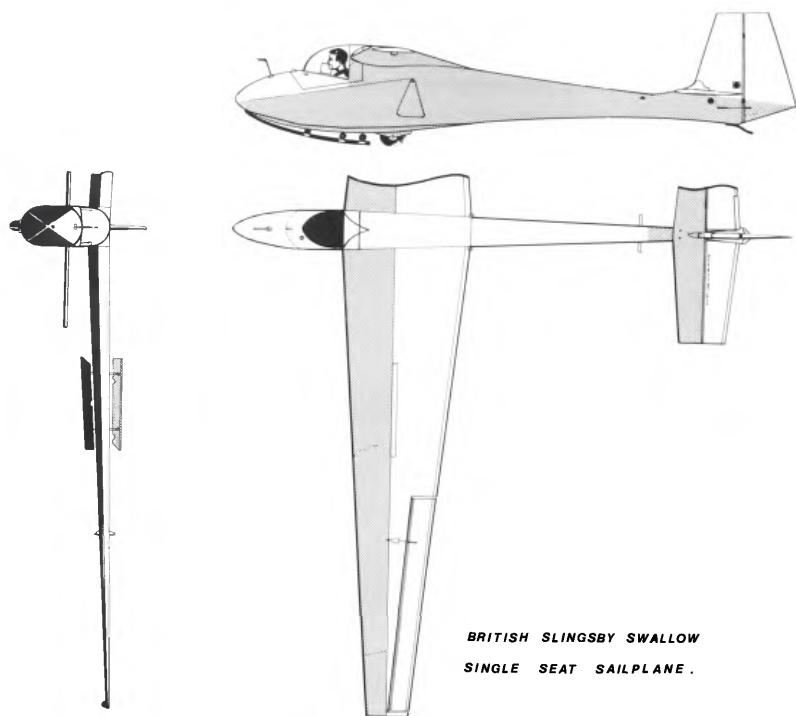

BRITISH SLINGSBY SWALLOW  
SINGLE SEAT SAILPLANE.

circuit. I suddenly realised there was a falling-off in the speed. I lowered the nose and the cruising speed crept up to 40 knots. I re-trimmed for that speed and then became aware of the marked nose-down attitude which is characteristic of the 'Swallow'.

I noticed too, that for a similar amount of stick movement used on the K-13 the response of the ailerons was far greater on the shorter wings. Shallow turns became medium turns and medium turns steep, requiring more speed.

There was little time to learn more, and in no time I had completed my final turn over the Beacon and was tucking the nose at about 20 degrees into wind to allow for the cross-wind landing. The grass snaked up and I rounded out, easing back on the stick and kicking off the drift with the rudder. The thing rumbled to a halt and deposited its wing tip on the ground. I switched off the electric vario and the turn and slip indicator and undid the straps.

The 'Swallow' was wheeled back to the launch point, and I com-

## CONVERSATION WITH MY HEADLESS COMPANION

pleted two more circuits that afternoon. Bad weather resulted in the restricted opportunity of only two more 'Swallow' flights that year, and I endured a wait of some three months before passing a check flight in the K-13 at the end of the following January. Once again trying my luck, which seemed at the time to be out, I had a succession of snatch launches and cable breaks. While good practice, it had become a little frustrating when trying to get used to a strange machine.

More bad weather followed in February and I had to content myself with the 'K'. On a visit to Lasham I managed to get a dual flight in a motorised glider with the jaw-breaking title of the 'Sheibe Falke'. It was great fun to fly, and a novel experience to fly from a different field, especially one that was enormously large and flat. I made a good week of it by returning to Firle to find the 'Swallow' had been damaged, and that the only machine for me to fly was the red and yellow T-21. I took a flight in it with an instructor, and asked if I could fly it solo with the spare cockpit suitably filled with strapped in sandbags to represent the weight of the absent instructor.

It seemed it was 'on', and so 'old sandbags' was duly strapped in looking like some headless Horseman of the Apocolypse next to me. With a gay 'All Out', we were off.

It felt quite different in the old 'bucket' flying it solo. It was quite good for one's vanity weaving the huge bird around the sky without any 'tut-tuts' from an instructor or cries of: 'I've got it. . . . Give it to me.'

I indulged myself in loud conversation with my headless companion.

'Did you know you left your head behind?' I said. And: 'Don't just sit there all fat, dumb and happy, say something, even if it's only goodbye.'

I continued with my childish revelry until it was time to land and treated myself to another flight in the 'bucket'. This was to be my last in her, as her appointment with the scrapyard after her final accident was drawing nigh.

---

## A bad example

---

Intermittent bad weather took us into May, and I was getting on for my fourth year with the club. The only 'shakers' I was experiencing now were from rough thermals. These I either abandoned owing to the turbulence, or else I found I could not manage to stay inside them. My confidence was growing, and I became thermal conscious and thermal greedy, to the extent that when I saw the tell-tale puffs of cumulus forming I would rush to the 'Swallow' and attempt, all too often unsuccessfully it seemed, to contact the elusive lift.

It doesn't pay to 'rush' with flying. There is always another thermal and always another launch. If the worst happens in a crash as far as I know there is no second chance, and at the best no excuse for smashing up a glider even if you manage to survive unharmed yourself. On this particular Sunday I began by setting an unfortunate trend in the club's flying habits.

The thermals were bubbling, and in a check flight in the 'K' I had already stayed up 10 minutes in the lift but abandoned it to get down quickly and land so that I could repeat the performance in the 'Swallow'. I grabbed willing helpers, got the 'Swallow' lined up, and snatched the parachute, swinging it over my back and clipping the straps home.

'Mustn't forget the safety clip on the 'chute,' I muttered to myself, fitting a thin sliver of metal over the lock. I checked the controls visually from outside the cockpit and adjusted the rudder pedals before quickly seating myself and securing my straps.

## A BAD EXAMPLE

'Controls . . . O.K.,' I muttered, going over the checks required for pre-flight. 'Ballast . . . O.K. . . . straps . . . nice and tight, in case we get chucked about . . . instruments . . . ' I went on, fiddling with the knob to set the altimeter at zero. 'Trim, a little forward of neutral . . . can I have the canopy on?' I shouted and the perspex hood was slid over my head and into place. I locked it saying: 'Canopy on and secure.'

The final check was the airbrakes and a member stood by waiting to put on the towing cable. I switched on the electric variometer, and the needle comfortingly sprung up to zero.

'Brakes,' I said to myself, 'check their operation . . . O.K. . . . forward and. . . '

Then there was an interruption.

The blue-overalled figure outside the cockpit said: 'Have you done the cable release checks?'

'Yes . . . yes,' I nodded impatiently, squinting through the canopy at the bubbling cumulus still forming up over the ridge. 'Cable on . . . come on man . . . cable on.'

I pulled the yellow knob back and he bent down. I heard the linked rings go home and a shout of: 'Closed.'

'Closed,' I repeated, and let go of the yellow knob.

With my left hand I quickly ushered him out of the way and went through the 'All clear above and behind' bit, and the 'Take up slack'.

The cable ran taut.

'All out,' I shouted, and concentrated like a monkey catching a flea.

The 'Swallow' made a nice ground run, and with the controls central rose slowly into the air. I allowed the usual 100 feet to get clear of the ground, and eased back into a steep rocking-chair climb. I became annoyed: the climb was steep but I must have been launching through sink as the altimeter seemed sluggish and I still only had 400 feet on the 'clock'. I looked out of the canopy at the ground below but my judgement only served to confirm the reading of the instruments: a bad climb.

After what seemed an age, and with the stick right back on the stop, I finally levelled off at 700 feet. Disappointing, I thought, as the higher one can get on the launch the better the chance of contacting the thermal. I pulled the yellow wooden knob twice but there was no bounce into the sky in the usual bouyant fashion.



'Lousy bloody sink' I said to myself and turned along the ridge towards the hangar.

The thermals were everywhere dancing in Will-o'-the-wisp abundance, but a squint at the variometer told me I was going down at six feet per second . . . 'Strange', I thought.

On reaching the hangar over Bo-Peep hill my thoughts were interrupted by an ominous clanging and banging from the wings. 'The bloody wings are dropping off,' I said aloud to myself, and looked out along the left wing, and there dancing gaily in and out like a pair of giant nut-crackers were the airbrakes which I had so carefully shut . . . but in my haste had failed to lock . . . Just about the most cardinal sin in gliding, and the sort of error committed by pilots on their first few flights . . . not their 242nd.

With a lightning left hand I closed and locked them and the 'Swallow' bounded up a few feet. But the altimeter already showed I was down to under 500 feet, and it was time to go home.

I knew that what I had done had been witnessed from the ground, and that the brakes had come out, sucked by the airflow, on the launch. Oblivious of the open brakes if I had experienced a cable break, I should have plummeted straight into the ground, and should have finished up a corpse with a very surprised expression on his face. To add to the fun I had failed to notice the problem until half way along the ridge, even with the vario nudging me and the altimeter assisting it.

I made a tidy circuit and landing, and sat in the quiet cockpit listening for the thudding footfalls of an approaching instructor. I went over the problem in my mind.

It was all due to haste.

I had been in such a goddamned hurry that I had completed a cockpit check with more thoughts of the thermals than what I was doing, and had relied on habit to complete them properly. Admittedly someone had interrupted me, but this was not his fault as the onus was on me to ensure that my checks were satisfactorily completed. I had closed the airbrakes with the long broom-handle lever in the cockpit, but had not pushed the knob onto the over-ride section for locking.

The awaited footfalls of the quickly approaching instructor were heard, and his rather serious face appeared at the side of the canopy which I unlocked and removed. He reprimanded me, and said that I would have to await the decision of the Chief Flying Instructor

## A BAD EXAMPLE

when he showed up on the field. George would decide what was to be done with me.

While I waited in blazing May sunshine other gliders quickly took off and soared up out of sight in the gaily rising thermals. I swore an unprintable word and plonked my bottom on the grass to wallow in my own misery.

George duly arrived, and shrewd soul that he is merely nodded as I admitted the error and agreed to abide by whatever reprimand he thought necessary. I had known cases of pilots being grounded for as long as a month for this misdemeanour, though I failed to see what good results from it, as it only keeps the pilot out of the sky for a long period and allows him to get that much more out-of-practice. 'You're grounded for three hours,' said George. 'Until two o'clock, when, if I'm any judge, the sea air will have come in and killed the thermals anyway.'

At precisely two o'clock the sea breeze front arrived, and the thermals ceased. The gliders were soon deposited on the ground, as they all rushed for home in the quickly sinking cool air.

I fought for the rest of the 'summer' (if that word can be described for English weather) to get into the thermals, but I lacked the expertise and only managed to push up my maximum duration to six minutes, instead of four. Then by some miracle I managed a seven-minute flight and in September . . . double figures . . . *ten* whole minutes ridge soaring late one evening.

I became despondent again. Four years' gliding and the best I could do was ten minutes. Others who had joined long after me had done five hours and become instructors by now. I managed some more '7's' . . . '6's' . . . and '9's', before winter closed in, and in the absence of north-easterly winds continued with the usual 3 and 4 minute circuits.

If I had my problems so did some others, and we discovered that rough ground, long grass and low wings don't mix. The K-13 was being launched with an instructor in the back seat and a pupil in the front. The pupil was doing the flying, and I was filling my mouth with a lunch-time sandwich signalling the winch for take-off. The K-13 was launching south through some very long grass and it was imperative that the low wings were kept level to clear this grass. The 'K' got off the ground a few inches. Then the pupil allowed the left wing to drop and it promptly became embedded

## GLIDER PILOT

in the clutching green tentacles. The right wing went up into the air, and the whole machine rose horrifyingly, until I could see it in the plan view with the nose crashing down onto the ground, the cable still pulling it along and raising the tail into the air. I flashed the stop signal to the winch the moment it happened, and as the towing cable stopped the K-13 instructor pulled the release, leaving the glider standing vertically up on its smashed nose with the wind holding the tail upright in the air. The whole aircraft just stood there perched on its nose for what seemed an age, before the weight of the tail overcame the wind and went crashing down onto the ground, smashing the tail and twisting the fuselage.

By some miracle we extricated the two occupants, who received nothing worse than a severe shaking. But the aircraft had to go away to Lasham for extensive repairs.

Some time afterwards the K-13 performed a similar 'prank' in exactly the same circumstances, but with less damage. The object lesson is twofold: in these circumstances keep the wings level and one hand on the cable release . . . and more important still . . . be ready to use it.

I contented myself flying the 'Swallow' on circuits at the beginning of the winter and felt completely confident for the coming season. On the 20th November I was even congratulated by *two* instructors on the quality of my flying, and I abounded with happiness and well-being. A red light in my memory should have flashed a warning to be resolute and alert in the immediate future.

At least out of my previous misdemeanour had come good. I had set an unfortunate trend in the airbrakes episode and two or three others had compounded the same mistake on the same weekend; the net result was an addition to the launch routine which now necessitated the person putting on the cable asking: 'Are your airbrakes closed and locked?' An affirmative must be received before the cable is attached.

In the morning I had been congratulated on my flying. We had been launching again along the ridge of hills from Bo-Peep Hill to Firlie Beacon into the westerly wind, and after lunch as a front moved in the wind freshened and backed to the south-west. However, by altering the landing run only slightly it was possible to fly a similar circuit as that flown in the morning, even though the winch was moved to facilitate a more southerly launch. My circuit

## A BAD EXAMPLE

on this occasion was a southerly launch. After any lift was finally used up I would use the down-wind leg to take me back to the crest of the hills with the valley beyond. The plan was to make a cross-wind turn and fly along the ridge with the valley on my right and the landing field on my left. I would then turn in at a suitable point and land towards the south-west in a slightly cross-wind landing.

After lunch I had been driving the tractor, and as it turned colder I fitted my leather helmet over my other hat to keep out the wind; in doing so I became unaware of the freshening wind, and when the 'Swallow' became available for another flight I leapt eagerly from the tractor and into the glider. It wasn't until I was in the aircraft with the canopy in position that I released the snap fasteners on the leather helmet, and even then I was only vaguely aware of the freshening wind.

The launch was not bad, though it was a fast one and took me to 900 feet in no time. I released, flying towards Newhaven and watched the vario settle to zero and stay at '2-up' as I began to gain height in a slight amount of wave lift. This lift is provided on generally stable days, when there are no thermals about and a high wind turns into a wave pattern in the lee of some obstruction like a range of hills or coastline. The lift is normally smooth all the time you are in it, but rough and turning into sink when straying into the trough of the wave. The wave is used by the glider pilot like an invisible hill and he flies up and down it as though hill soaring, which I promptly commenced to do on this occasion.

I gained height to 1,100 feet and then lost it as I slid out of the invisible lift. This was only the second time in my life that I had ever contacted wave, and my prowess in its use was lacking. I found it again by chance and after sinking to 800 feet rose again to nearly 1,200 feet, only for the whole system suddenly to cease functioning. I gradually lost height until it was time to turn across wind and look towards the field to consider my circuit. Even as I flew across wind there was considerable drift of the track of the glider over the ground, but it failed, at this stage, to impress me.

I turned down wind and joined my circuit, making a mental note to turn over the crest of the hill, and commenced my pre-landing checks.

'Undercarriage . . . fixed' I said to myself, 'speed . . . increase from 40 knots to 50 knots . . . trim accordingly . . . hand on airbrakes lever . . . ready . . . and a good lookout for other aircraft.'

I watched the crest of the hill coming towards me and felt unconcerned at the high ground speed I seemed to be making: the altitude decreasing.

I suddenly hit severe turbulence, and on making the hill I commenced my turn across wind.

The happiness and well-being of but a few seconds previously turned suddenly to agonising concern as the curl-over from the high wind swept me over the side on the hill and I ran out of speed, altitude and ideas, all at once. When the wind blows away from a hill it has the opposite effect to when it is blowing against it, and rather like a stalled wing the air blows down in turbulent rotors. It breaks up the smooth airflow into turbulent eddies in all directions.

I glanced out into the valley, deciding to land out, but the decision was quickly countermanded by what I saw. Layers and layers of mist obscured the fields and would result in a crash landing, at the best, and a fatal tangle of twisted wood and pilot, at the worst.

I pushed the stick forward to gain speed but the A.S.I. stuck at 38 knots and falling. . . . The chalk pit, which was cut into the side of the hill like some sheer giant bomb-crater, loomed up ahead.

Many times I had wondered what my reactions would be if I ever got into a really tight and dangerous position, and now I was to have a chance to find out. Would fear and panic seize me once again? Would I find myself seizing up solid over the controls, unable to make any decision or sensible manoeuvre? Would I merely plummet to my doom, as a terrified and futile observer of my fate?

As I sank over the hillside the air felt calmer. I was suspended in its unhelpful void, but I should not remain long suspended unless I took some positive action.

I swept the glider into a shallow turn and aimed at the car park, but the shuddering I could feel meant the approach of the stall and catastrophe was not far off. The stick was well forward and yet still the speed did not build up. The car park disappeared from view, and the shadow of the hills darkened the cockpit as they rose above me. I noticed the altimeter recording *minus* 50 feet from the take-off setting, and I saw the chalk pit looming up dead ahead of me now.

Surprisingly, I felt no fear or panic and experienced a feeling of quiet well-being, as though I were indeed an observer remote from the danger and watching the forthcoming result with complete detachment. My only conscious thoughts were now quite calm and unemotional.

## A BAD EXAMPLE

'What a pity . . . I'm going to crash . . . I hope it doesn't hurt too much.'

My last final and futile decision would be to try and turn the stalling glider away from the chalk pit at the last second. Even spinning into the gaping jaws of chalk and grass would be preferable to hitting the thing head on. . . .

My thoughts were interrupted as the sound of beautiful and delightful whistling speed reached my ears. A glance at the airspeed indicator confirmed that at last the 'Swallow' had 'bitten' into the airflow. The precious instrument read 70 . . . 80 . . . and 85 knots (ninety-eight manipulative miles per hour), which if I were careful, calm and skilful . . . and terribly bloody lucky . . . I just might have time to convert into height and get myself over that dark hill.

I was now flying up the road that led to the car park at the top, with my left wing a little too close to the hillside and still going into the larger-than-ever chalk pit. . . . I eased back the stick gently, as the fast airflow at that speed made the controls respond quickly and with greater effect.

The 'Swallow' showed a sudden instinct for self-preservation and rose. Somehow the speed held and in seconds I was level with the car park. . . . I turned a little towards it, remembering that the ground on the far side of it was higher and fronted by a tantalising fence post. As I aimed like a Bisley marksman at the corner of the car park, I simultaneously saw a number of things happening.

Little blue-overalled legs were running from the hangar next to the car park, whirling like helicopter blades as their owners sought salvation. I also saw an individual in the car park watching me. My approach in an aircraft, which is at the best noisy on normal approaches of 50 to 55 knots, must have been terrifying with the banshee wail I was making, flying up the road and suddenly into his view. I wonder what his thoughts were?

He threw himself flat into the mud!

I could also see bodies pulling another glider up the field in front of me. They quickly left it to its own devices and ran like rabbits.

I squinted my eyes, held my aim at the fence post in the corner of the car park, and easing back, holding steady on the stick, I tried to miss it by about six inches and pull up very slightly over the higher ground behind it. The fence post looked like a tank trap as it came towards me, then suddenly it was gone under the nose of the glider, and with a further fractional pull back on the stick I cleared the high ground behind.

Acres of open field were in front of me now, and I rather grabbed at the airbrakes which deposited me on the ground with a huge bump . . . I closed them quickly and shot back into the air a few feet before opening them more gently, holding the speeding 'Swallow' off the flashing green lines of grass as the ground swept past a few inches away.

Surprisingly gently, the 'Swallow' touched the ground and rumbled along on its single wheel as the speed dropped off. It stopped, facing into wind and very slowly eased the right wing tip onto the grass.

The perspiration flooded from my face and neck. My body felt as though a fire had been lit inside my flying clothes.

I had landed some way from the parked gliders and people, and was thankful for these few minutes respite as I undid the seat straps and parachute harness. With a hot clammy hand I switched off the electric variometer.

Strangely, I felt nothing at all emotionally. The only quiet words I said to myself were: 'Bloody hell.' Ironically, it was from 'bloody hell' that I had just escaped.

There was something to be quickly decided, though. I had to make a diagnosis. What had I done wrong?

Drift . . . I had not accounted for the fact that I should have commenced my turn on the cross-wind leg earlier, letting the drift take me in the turn to the correct position above the crest of the hills. I had, in fact, started to turn on the hill itself, and the drift had swept me out into the valley. I had only myself to blame, as I had received plenty of warning from the drift I had experienced over the ground before I had even started my down-wind leg. Added to which my ground speed coming down wind should have reminded me that the wind had increased since my take-off.

I pulled the leather helmet from my head and deposited the canopy onto the grass. The high wind hit me violently in the face and rocked the 'Swallow' to and fro' on the grass. The heavy thudding footfalls of approaching helpers reached my ears, and I turned in the cockpit to see one of the instructors looking down at me with an ashen face. He appeared as though he, and not I had undergone the experience.

'You're lucky to be alive,' were the words with which he greeted me, adding: 'I had written you off.'

'I failed to account for the drift,' I said, ensuring that at least he knew

## A BAD EXAMPLE

I was totally aware of the reason for my error.

'Hello, "Death",' smiled another pleasant character.

A woman-member of the club joined in, maintaining: 'I expect the shock will set in and you'll faint shortly.'

'Not on you, if I can help it, madam,' I replied, extricating myself from the cockpit. As we began to wheel the 'Swallow' back to the launch point, the instructor explained some of the shock that he was exhibiting.

'I thought you had landed out in the valley,' he said breathlessly, as we heaved the glider up the sloping ground. 'We all went rushing up towards the hangar and you came flying up the hill and over the car park with the most almighty screaming noise I have ever heard. Well, at least you know what you did wrong: how do you feel?'

'Numb,' I said truthfully. I had expected shaking legs and palpitations, but I felt nothing at all, only a mere awareness that I did feel nothing at all.

As we reached the launch point and the other gliders we were joined by another instructor.

'I think you have set the other pilots a bad example,' he said loudly, 'and I think you had better come and fly with me in the two-seater so that you don't lose your nerve.'

'I am not losing my nerve,' I replied, 'only a great deal of patience, and as for setting bad examples, the only thing I shall set round here will be your head in cement if you have any further amusing observations to make.'

'If you don't fly now,' he snorted, 'you may never feel like flying again.'

'I wouldn't lay your money on it,' I advised him, and walked slowly across the field to my car.



---

## Thermals popping up

---

Bad weather dogged any further flying over the next few weeks. I awaited a reaction arising from my recent experience, but it was not forthcoming at the time.

The one factor that seemed to impress itself on me was the wretched chalk pit. However, this in itself was only a frightening back-cloth to the experience, and in no way a cause.

A few weeks after my near fatal flight (number 309) I again turned up on the flying field and expected to be returned to the two-seater trainer. Instead, I was told to fly three consecutive circuits, which took me over the chalk pit on each occasion. I found I had a 'thing' about the chalk pit and every time I flew over it for some months to come I would feel my stomach revolve.

The following week I did spin practice and 'unusual attitudes' in the K-13. If I didn't impress anyone I didn't kill 'em either.

The chalk pit episode was, however, to spoil my flying. Launching and landing in the same pattern as on that occasion, I learned the lessons of drift, curl over and low altitude to such an extent that I began to come back down wind too high, too fast and turn in too early. All of which, as I say, tended to muck up my flying.

Others apparently, still had their little moments of anxiety. For example, one day there was a high wind, and it was decided to use the bunjey launch.

The bunjey launch is put into operation by taking the glider on the ground to the crest of the hill. It is used when the wind is howling

## THERMALS POPPING UP

against the hill-side. Sitting the occupant or occupants in the machine, a powerful rubberised rope is attached to a hook on the nose. The tail is held by a number of stalwarts, and about another three or four form out in a 'V' shape in front of the glider, one end of the tow rope in the hands of each team. On a signal from the cockpit the tail-end-Charlies release the tail, and the two outboard teams run down the hill catapulting the glider out into the valley. At the same time, it is hoped, the resulting lift will take it to maybe 1,000 feet or more.

On the day chosen for this sport the red and yellow T-21 was made ready. The occupants were to be an instructor and a young girl, who was a journalist. The instructor explained to her the mechanics of bunjey launching, and warned her that they must keep the nose down until well out from the hill so as not to stall the glider. He continued his explanations as the gale force winds tore at the machine and the helpers hung on for dear life.

A sudden gust of wind funnelled up the hill and smacked into the poor old 'bucket', lifting it, its occupants and the wing-tip man from the ground. The wing-tip holder decided as he left the ground and rose up that he had held the tip long enough and let go, to fall and sprain his ankle on the hill below.

The bunjey-rope launchers scattered and fell as though hit by automatic gunfire, while the tail-end-Charlies split into two diving sections. The wind continued to carry the T-21 up and, more frighteningly, over, in an almost complete loop behind the hill, depositing the 'bucket' and its occupants upside down in a gorse bush, the rear fuselage and the wings snapping off.

Miraculously, neither occupant was hurt, and to break the tension Jim, the instructor, turned to his upside-down young lady-journalist and said: 'Remind me to talk to you about your landings. . . .'

And so, the old 'bucket' like its predecessor, went to the 'knacker's yard'. It was comforted, no doubt, by the thought that at least it had done no real harm.

It did seem a shame, though, when these old gliders finished their lives. The previous T-21, spun in by the pilot who confused ground speed with air speed, had made over 60,000 launches and was over 20 years old. This present example was eleven years old. Alas, the ravages of time tell, and the diminishing number of T-21s only serve to make them more interesting machines. One wonders just

how many pilots these immensely strong trainers brought to solo standard. Their strength is illustrated by the fact that one night many years ago the high winds collapsed the club's hangar roof. On opening the hangar doors at the week-end there stood the old T-21 with the wings completely supporting the broken roof!

The replacement for the '21' was the more advanced K-7, a similar aircraft in appearance to the K-13, but with high wings and a slightly lower performance. In addition, it sported a cockpit canopy and airbrakes instead of an open cockpit and spoilers. It would appear to have been a more useful training machine than the old '21'. It also sported the registration 'D-1773' on the wings and 'Lufthansa' on the fin, plus the West German colours, and we came to the conclusion on its arrival that it had been hijacked. . . .

Meanwhile . . . back at the 'Swallow' . . . I still tried vainly, it seemed to get any duration whatever. As my five years with the club loomed up, there was another problem. My eyesight went a little wonky, and my landings were somewhat picturesque, to say the least. Also I felt extraordinarily tired, and became aware of a great thirst and sore tongue. A trip to the doctor was in order I thought; to get a few pills.

'Diabetes,' said the doctor.

My thoughts consisting of the 'green ball', 'lift' and 'thermals' plunged into despondency, 'red balls' and 'sink'.

'Can you fly with diabetes?' I gasped.

'Dunno,' he replied, and there followed hospital tests, and each time I asked the examining doctors about flying they too would join the 'dunno' brigade.

I reluctantly, though voluntarily, grounded myself, informed the club of the 'bug', and awaited results of the tests. Fortunately, they proved that I had not got the wretched complaint too seriously, and that I could be treated by diet only, at least unless the complaint manifested itself to a more disagreeable degree, which, to date, thank God, it has not.

I finally asked the specialist: 'I expect you "dunno" too, but can I fly gliders as a solo pilot, and can, and will, you send my C.F.I. a medical certificate stating that I can. . . . Can I?'

She must have thought me potty, but bless her heart, she said I could fly solo, and sent the C.F.I. the certificate.

Having lost weight rapidly for a few weeks I again clambered back onto the flying field.

'I hope you won't be affected by flying,' said one instructor.

'Oh no,' I rejoined.

'You won't see coloured flags or anything like that, will you?' he enquired.

'Only Union Jacks I promise you,' I told him, and had a check flight in the K-13 to make sure I hadn't lost any judgement over the eight weeks I had been off flying.

I landed, climbed out and watched the K-13 dragged back to the launch point to be got ready again with another pupil. This time it caught its wing in the grass and ground looped. It crashed to a halt, which did sufficient damage to the machine to necessitate its being dismantled and put on the trailer ready for the Lasham 'surgeons'.

Still, I thought, it was an ill wind that blew nobody any good, and at least I had my check flight in the old bus before it piled in. I then unerringly climbed into the 'Swallow'.

I launched with a great feeling of well-being, but was now sophisticated enough as a pilot to remain alert and observant lest I got caught out again. The exhilaration of the launch was something that I had missed in the preceding weeks, and the 'Swallow' and its occupant rose happily into the blue.

I got rid of the cable at 800 feet and throttled back quickly but did not trim accurately, and only to the usual trim lever position, which had been satisfactory for my original weight of 175 lbs., plus 20 lbs. for the parachute. It was wrong for my present weight of only 154 lbs., plus parachute. I let go the stick in the usual check to see if I was correctly trimmed, only to see the nose rear up. I hastily grabbed the stick back and corrected the fault. I re-trimmed with more care.

I was still recording some awful times in the 'Swallow' and was getting pretty fed up with myself, when I managed to 'scrounge' a rather nice evening flight in a powered aircraft. As an aviation artist I had a customer who wanted a painting of his Cherokee 'Arrow', which was based at Shoreham. I convinced him that if I had a flight in the aircraft I would paint him a better picture. He agreed. I only wish Canadian Pacific and Hawker Siddeley along with a few others of my customers could be so easily convinced. However, I enjoyed a pleasurable half hour flying over Sussex in the 'Arrow', and found it a lot easier to fly than a glider. A little more expensive, too, I daresay, if I had been paying for the fuel.

I made my 351st flight in a glider on the 12th August, and so

celebrated my five years with the Club in an awful five-minute circuit. I had to get cunning, and I began to study the weather and the forecasts.

On the evening of the 26th August the forecast was for high pressure and high winds—north-easterlies, no less—and with an early rise I made sure I was one of the first on the flying field that Sunday. As we extricated the gliders from the hangar I had my eyes on the sky, and for once the forecasters were right. Clear blue skies contained little thermals popping up here and there and a north-easterly that was getting stronger by the second.

First come: first served, and I was in the 'Swallow' ready for the first launch of the day, remembering this time not to rush and going through the pre-flight 'checks' thoroughly, and twice, to make sure. I tried to remember all the things I had been told about hill soaring, the flying rules . . . what happens when aircraft approach each other head-on (both turn right) . . . always give way to the aircraft converging from your right . . . all turns to be made out from the hill . . . overtaking other gliders to be between that glider and the hill . . . fly in and out the spurs of the uneven hill and keep the turns shallow . . . increase speed if you get too low and close to the hill . . . and don't leave your landing too late . . . keep a damned good look out all the time and keep away from the top of the launch point.

I tested the cable release, called out the pre-take-off signals, and with a rush, the 'Swallow' and I were away. The climb was normal, though the winch sluggish and it was with disappointment that I found I had only 750 feet at the top of the launch. I looked along the wings to ensure that I hadn't forgotten those brakes again, but, no, they were both firmly retracted and locked in the wings. I got rid of the cable with two annoyed tugs on the yellow knob, and I was free.

I turned east towards Alfriston, which lay at the end of the ridge, and suddenly felt the surge of lift and noticed the vario telling me I was going up at six feet per second. As I approached Alfriston I continued to climb for the next minute-and-a-half. I rose to 1,200 feet and about 1,600 feet over the valley. As I turned back I maintained the height all the way to the Beacon, about two miles, and turned again to repeat the beat back. But the lift became variable and I was still unable to make much of the thermals on going out into the valley to try my luck in them. I found I was in sink and returned to the support of the hill lift, but was now down to 700 feet

again. It was then that I had to start working for my living: gently applying bank and carefully turning with not too much rudder. I watched the bubble balance on the turn and slip to ensure that my turn was accurate.

Hastily screwing my neck round it seemed the sky was suddenly filled with gliders, all making use of the conditions. Every time I found a patch of rising air I was surrounded by 'parasitic' pilots intent on getting in on the free ride up.

Manoeuvring in and out of my friends I could not make the most of the conditions and sought solace further along the hill. I gradually climbed back to 900 feet, only to find the K-13 performing a loop some way in front of me, making me divert to another course and so lose the lift.

I must admit that I enjoy flying with other gliders on a ridge-soaring day. For some silly reason I always feel compelled to wave to other pilots as we pass one another, only to be brought 'down to earth' as it were, by receiving the inevitable 'V' sign in exchange.

What with 'V' signs and erratic lift I had sunk yet again to 700 feet, and even with the most exacting turns I could inflict on myself I still began slowly to lose altitude. There I had been, high above all the others, and now here I was sinking like a stone in a pond. I watched frantically for the 500-foot mark, which would mean starting my landing circuit. I sank to 500 feet and hung on for a few minutes in the hope that I should find lift and go up again, but it was 'not-on' that day, and I turned out from the ridge, keeping a good look out and making a full 360-degree turn. I made my down-wind leg, cross wind and final turn with quite a respectable landing.

As I rumbled to a halt I consulted my watch.

Twenty-three minutes from start to finish. Not bad, perhaps better next time. But there was to be no 'next time' that day, as more and more 'Swallow' pilots turned up to fly the club-owned machine and the conditions improved with some of them recording two hours or more in the air. Still, I was getting the idea.

The following weeks were followed with slightly better average flight times as I clocked many 10-minute trips. Then I scored another twenty-five minutes ridge-soaring, followed by 27 minutes in September, in a thermal-strewn high wind on an altogether rough and turbulent day.

I was to end the season on a real corker of a flight though not a long one. I made three flights in quick succession to try and contact

big thermals. These were passing over the airfield and going on over Eastbourne to build up into thunderheads. I failed to contact any sizeable lift, and on the fourth flight I tried launching just after the cloud had passed, as I reasoned that as it was drifted by the wind the lift would be 'bent' and therefore it would be upwind of the cloud.

I duly launched and immediately found myself in 'off-the-clock' lift on the variometer, and started turning. The launch was a poor one to only 700 feet, but in seconds I was climbing past the 1,000-foot mark and over the other parked gliders on the ground. The vario went mad and the glider bucked and pranced all over the sky. I tried to hold a steady turn at around 50 knots, attempting to take a few colour photos at the same time. I gave up any further thoughts of photography as the 'Swallow' became almost uncontrollable. Pitching and bucking, I frantically tried to maintain the right attitude, and the seat straps creaked and gave a little as I was thrown about in them. Eventually, they loosened to such an extent that when I hit fantastic sink, as the thermal spewed me out of its clutches, my backside came off the seat of the cockpit and banged my head against an already repaired canopy. It cracked a second time with a sound like a pistol shot, letting in a rush of noisy air as the two sections of perspex moved against one another.

The altimeter unwound and I dropped like the proverbial brick. Then I hit another up-coming layer of air with a thud that felt as though I had contacted the ground.

When I finally sorted myself out I found I was too far from the field, and put the stick forward and the speed up to get home. The air in the cracked canopy whistled an even shriller note.

On landing I got out and looked up at the fast disappearing cloud that had thrown me about, and watched it as it built into a blackening thunderhead. I was surprised that the flight had only been of ten minutes duration, although relieved looking at the fast-building cloud that it hadn't been any longer.

As the short soaring season closed thoughts were transferred to another endeavour. This was now fast approaching: the big flying meeting at Firle to celebrate fifty years of gliding.

---

## A day in a lifetime

---

Seven years before I was born a small band of pilots were gliding from Firle Beacon (and making a better job of it than I am fifty years later). They were competing in October 1922 for the £1,000 prize put up by the *Daily Mail*. This was for the longest glide exceeding thirty minutes in duration.

The operation, conducted by the Royal Aero Club, was to be furnished on Itford Hill, near Lewes, on the slope of land near the River Ouse facing westerly, to catch the prevalent 'sou'-westers', but English weather being what it is the 'nor'-easterlies began to blow, and so the show was moved along the downs a few miles to Firle Beacon.

Surprisingly, as many as thirty-five gliders were entered for the competition, and Alexis Maneyrol from France won the event, recording three hours and twenty-one minutes. He broke even the existing German records at the time. I wish he'd show *me* how to do it. . . .

Also from Itford, the legendary Robert Kronfeld, in 1930, flew a glider to Portsdown Hill, near Portsmouth, 50 miles away. There are a few of our present day members who would be proud to have the ability of making a similar flight forty years later in gliders of greatly advanced design. The events of the early pioneers are covered in *The Story of Gliding*, by Ann and Lorne Welch, if you are interested.

In early 1972 Derek Eastell, one of the club's more recent instructors, proposed a fifty-year celebration meeting to com-



memorate the Itford Meeting of 1922. When his proposal was finally adopted he burned much midnight oil in organising the whole affair. It was, unfortunately, based on an extremely odds-on gamble . . . the English weather!

Would it, in fact, stay fine enough to attract the British public in sufficient numbers to make the meeting a viable proposition? Would the weather, even if fine, be of sufficient calibre to support gliders entertaining the fickle interest of a public really uneducated regarding gliders and their functions? Would enough owners of old and vintage gliders be attracted to the meeting in sufficient numbers to provide an obvious link with the machines that operated pre-war and nearer the Itford days?

An awful lot of 'ifs', and Derek wore an unusual amount of frowns upon his face during the intermittent months while futile discussions took place among the club members regarding the possibilities of the weather for the date set, which was an ominous *September 3rd*, or as one member put it: 'The day War broke out . . . and the day our Bank Manager will break out if it rains hard.'

During the last few days of August the wind and weather varied with north-easterlies and south-westerlies, and the possibilities of the weather on 'The Day' became as subject to conjecture as the numbers turned up on a roulette wheel.

The visiting gliders were due on Saturday, September 2nd, and the field looked frightfully 'anxious' early that morning. The marquees and the loud-speaker system were standing proud of the long length of field roped off for parking the intended thousands of cars that we *hoped* would come the next day. The whole club membership turned out, to be allocated jobs which were rehearsed that day to ensure no last-minute hitches, even to the extent of grouping numbers of member's cars together to provide parking practice for the 'stewards'.

I was to run the 'art exhibition' in the hangar, which by comparison to the others was an easy job. On the Saturday I arrived with great excitement as the north-easterlies started to blow against the ridge. If only it would stay that way for the next day. The Saturday was bright and sunny as well as windy when the visiting gliders began to arrive. They got rigged from their trailers, and their pilots were taken on check flights by our instructors, as many of the visiting pilots either had not flown from a ridge before or were a little rusty.

A DAY IN A LIFETIME

The numbers of gliders increased until in the afternoon there were nineteen soaring the ridge at the same time, from the yellow 1937 'Rhon Buzzard' to the pre-war German 'Minimoa', the latter designed by Wolf Hirth in 1936 and spanning nearly 56 feet. There arrived old 'Tutors', providing me with pangs of nostalgia, 'Olympias' in profusion, plus one or two 'unusual' designs, the most eye-catching being a machine that resembled a cross between a Canberra bomber and a Spitfire.

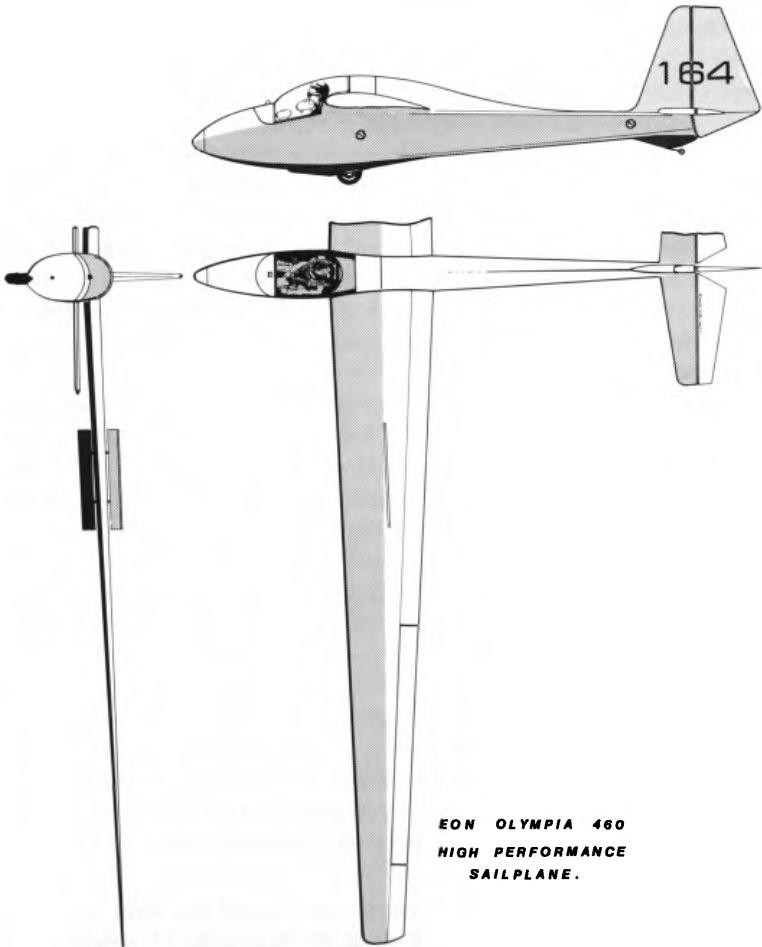

**EON OLYMPIA 460  
HIGH PERFORMANCE  
SAILPLANE.**

This last machine with a jaw-cracking German name that I found completely unpronounceable, sped in and out of the others being tested on the ridge like some preying shrike. It looked as though at any moment it would pin its prey against the side of the nearest hill.

It turned out to be one of the greatest days of entertainment I can remember in gliding, and I well recall the positive zest with which the young 'Rhon Buzzard' pilot extricated his glider from the confines of his battered trailer. He propped the fuselage upright on a small but useful trestle, while the wings were laid flat on the grass and the two halves of each wing pushed into assembly. The pair were held together by what seemed a disproportionately small steel pin that was hammered into place with a mallet!

The wings were then lifted over the fuselage and secured to the top of it and the struts placed in position. The tailplane was then attached, and the pilot, still running, donned his flying gear and climbed aboard. A strangulation cockpit section was put into place, and it left his leather-helmeted head just visible. We then learned he had never been winched up into the air in this particular machine before, and that the launch speed must on no account exceed 40 knots while the cruising and thermalling speed was in the region of 20 knots.

He duly took off to soar high into the lifting clouds and make one of the best flights of the day. The winch driver, Peter Gellett, had his work cut out as he finely tuned his winching to suit the many and varied types of glider. He coped with his usual professionalism on this day and on the following day's celebration meeting.

The pre-war 'Minimoa', recently rebuilt from discovered remains, was finished in fabric, well doped and giving a transparent gloss that was highly polished. This machine resembles a huge bird of prey in the air, and to me at least symbolises gliding at its best.

By mid-day the gliders were airborne in numbers, all doing well in the north-easterly winds on the slopes, and making use of the thermals as well. A great legion of 'Ancient Mariners', appearing to me like the pages from the history of gliding, paraded up and down the ridge, some breaking off into the powerful thermals and disappearing upwards.

I managed to grab the 'Swallow' and joined the long queue of gliders waiting for a cable. As I sat in my 'Green Ball Express' I felt

heartened at the opportunity of being able to fly in so distinguished a company, but, as they say, there is many a slip twixt' cup and lip. I had to give priority of launching to the visitors, and rightly so, but disappointing in that I could not join them up there.

Dusk fell and we still seemed to be busy. I left around 7 p.m., as I had an early start the following day. . . . What would that weather do?

It deteriorated, of course, but not to any damaging extent, and once I had the paintings hung in the hangar and all was ship-shape, I stood there eagerly awaiting the incoming cars. It was easy to judge the success or failure of the meeting from my vantage point. At 10 a.m. I began to wonder if the club would, in fact, go bankrupt, as only a trickle of visitors climbed the hill. Then, suddenly, there was a great flood of cars, even in a light shower of rain, and the flood went on . . . and on . . . and on . . . all day it seemed. The loudspeakers crackled out the programme, and the gliders took the air again in a fortunate north-easter and literally stayed up as long as they wished.

The programme included aerobatic displays, model aircraft flying exhibitions and visits by Fournier RF 4 power gliders, with a visiting 'Sheibe Falke'. They were all mixed up in the parade of the vintage machines along the hills with a brand new 'Cobra' racing in and out of the others like some zestful speed cop.

In the afternoon the Tiger Club provided contrast, with their famous aerobatic 'Stampes' complete with smoke trails. The vicious hill lift did not make their programme an easy one.

Two 'death-wish-Davids' launched themselves from the hill in delta-winged hang gliders, and somehow lived to talk about it afterwards even after plummeting into the gorse. While I am the first to pay my dues to courage and enterprise I am concerned about the present hang-glider craze. Any novice feels he can purchase or construct such apparatus and gaily sling himself off the nearest hill and emulate the birds without any previous experience whatever.

I hope that in the near future there will be some serious instructional articles in the relevant flying magazines. They should help illustrate the problems and demonstrate the techniques required for such flying, otherwise it may not be long before some poor soul plummets down like a dustbin from the top of a high-rise block of flats.

The day started for most of us at 7 a.m., and ended long after

8 p.m., but it was a day in a lifetime, and the heartiest congratulations were due both to Derek Eastell and all the club members on the one hand, and the Gods of Providence on the other for providing reasonable weather and those heaven-sent north-easterlies.

There were many famous names at this meeting, and it would be wrong to include only a few, so suffice to say that the 'Father of English Gliding', in the person of Philip Wills, showed great interest in the meeting and stood there gazing skywards, looking to me remarkably like Sir Francis Chichester.

The only great thrill left for me this winter was the aero-towing experience from Redhill, already described. But as I sit recording this in the depths of winter a few flights short of my 400 I hope I have entertained you. This is the function of this book. I also hope that you will be sufficiently enthused to try the sport for yourselves. I hope too that I have illustrated that I was a shocking pupil with all my idiosyncrasies. This too was intentional, as it must surely show that if I can do it . . . so then can you . . . and possibly a lot more quickly and a lot better than I have done.

There is one claim I will make, however, and that is I can assure you that you will never grasp quite as much the great joys and great love I have for this sport. This is the reason that most of us go on with the art of gliding. While it takes only a few of us from 'A' to 'B' we engage in it purely for the sake of it. The sense of freedom at the top of the launch, the knowledge that any flight over three minutes is due to your own wits and weather sense are one thing, while the views, ever-changing in the different weather conditions, are sights that you must discover for yourself.

Should you think this sport too dangerous, try counting the near misses you have in your car in one week and you will find that it slips gracefully into perspective.



**Left: The author in flying gear.  
Above: Pop Orford leaning against the Tutor in  
which he completed over 300 flights.  
Below: Instructor Val Vanson.  
Bottom: Deputy C.F.I. Jim Tucker.**



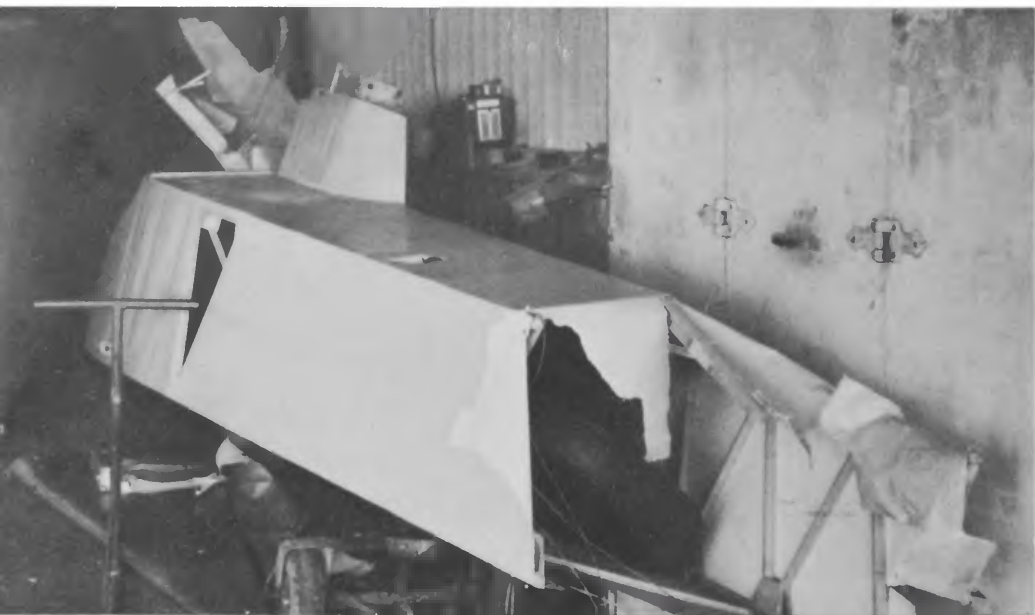



**Top Left:** A comparison of instruments; on the left K-13 and on the right the Tutor.  
**Left:** The remains of the second of the club's T-21s destroyed on a bungee launch.  
**Bottom Left:** The T-21 on a landing approach.

**Top:** The Swallow parked.  
**Above:** The Swallow being launched, showing the cable and drag parachute attached to the glider.  
**Below:** The Swallow in flight.







**Giders in flight.**  
**Left: K-13.**  
**Below: Olympia 460.**  
**(Instructor: Chris Berry.)**  
**Bottom: K-13 on a**  
**landing approach.**  
**The glider on the**  
**ground is a K-7.**

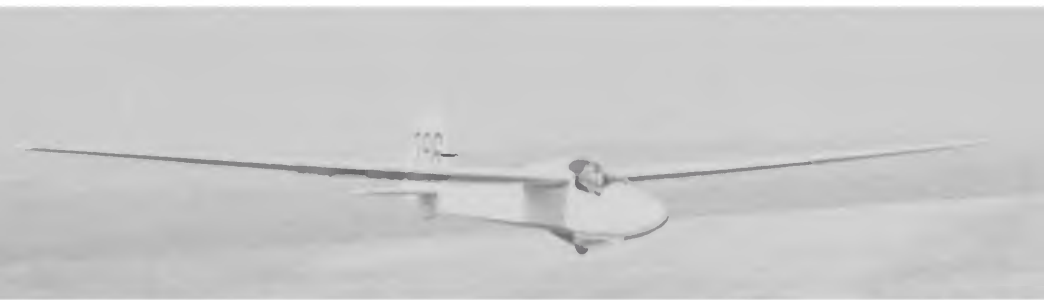

---

## The pilot who is never wrong

---

There exists a group of men in gliding circles rarely mentioned in gliding books, but I feel the last chapter belongs to them.

Where has that instructor got to? Why isn't he here at the hangar doors at 6 a.m., like he used to be in the old days? Why the devil must he keep criticising my landings? One damned instructor wants me to make turns like this, and the other says they are too steep and should be like that; do they really know what they want? 'Its four o'clock. I've got to pick my wife and the kids up in Brighton, so I'm off. See you next week,' I can remember saying on many occasions, and the instructor has grinned and nodded.

It strikes me as odd that there is never a shortage of men wanting to become instructors, and yet it can be the most thankless job in the world, largely unsung and generally unpaid. In just an average day at the weekend his routine will go something like the following.

The instructor arrives at the clubhouse at around 7 or 8 a.m., and checks on any messages left from the previous week regarding the state of the aircraft and equipment. He then makes a trip from the clubhouse to the hangar. He starts opening up and getting the daily inspections done on the equipment, providing there are enough pilots at that hour in the morning.

If there aren't, then the instructor must wait until there are. There must then be enough pilots and pupils to get the aircraft out under guidance, and they must be placed on the field for daily inspections. If there do not happen to be enough qualified people on the field to do these then the instructor must do them himself.

He then tries to decide on the weather conditions and where the winch will be placed, and which end of the field will be the launch and landing area. Having supervised the trundling of the gliders to their point on the field, he checks that the flight log, recording each and every flight, is made up, and that the signal lights are working and the towing cable is serviceable. He then looks around at the two-seater people and gets them organised into some semblance of flying order, and picks which solo pilots can fly the solo machines without check flights and which can't.

On each flying day he should have another instructor to relieve him every so often, but on this day the other chap has become confused, and thought his duty week was the one following this. So our instructor is on his own and details a senior pilot to ensure smooth running and ground handling, while he is giving air instruction in the two-seater. But if the senior pilot should make a mistake, the instructor is responsible.

He then starts to fly pupils on possibly three flights each in what may be circuits or sudden thermals, taking them to 3,000 or 4,000 feet. After an hour the feet will get cold and numb, and the instructor possibly a little weary of the pupil pulling high 'g' manoeuvres and experiencing generally uncomfortable flying. He will land and take the next pupil, and so on.

Around 2 p.m. he might get a cup of coffee and have time to push a couple of mutton sandwiches into his mouth, and he might in desperation call a halt for half-an-hour to gain his second wind. More often than not he won't bother, however, and so the day goes on, probably in T-21 open cockpits in all weathers. It goes on throughout the summer and winter and in the snow, ice and hail, for while there are pupils to fly, he must fly them.

During the downpours of rain he will, if lucky, be on the ground, sheltering under one of the large wings of the gliders. More often than not he is unlucky and in the air during the downpour, getting soaked.

As the sun thankfully sets, flying will trickle to a halt and most of the gliders are landed near the hangar, where the instructor assists putting them away and locking up all the other equipment. When it is dark and all the pilots have left the field, he too may leave to complete his interesting Sunday.

This is, of course, just a straightforward day when nothing goes wrong. If there is a cable break he must ensure that the cable is

## THE PILOT WHO IS NEVER WRONG

mended properly, and that the aircraft are thoroughly checked after heavy landings, as well as decide what briefing each pilot needs, or in which instances he needs none at all. Where pilots are attempting to fly cross-country he must ensure that the pilot has made his destination known, and that he has left the keys of his car with some responsible person who will assist in the retrieve. The trailer must be road-worthy and conform to all sorts of laws of which the instructor must be fully aware.

He will then possibly show interest in a pupil, who has been with the club for six months, let's say, and who has great promise and pretty near solo standards, only to find that the pupil has left the club to get married, go abroad or change his or her job and home. Then again, he gets a few like me, and possibly wishes some of the more difficult ones would leave. But of course they never do, and are merely the crosses that the instructors have to carry.

Occasionally he finds himself dealing with the pilot who is never wrong. The one who always has an answer for a bad flight, a bad landing, or bad judgement, who insists that when he came into land the field was clear and that that wretched cow ran out from behind cover determined to spoil his landing. Or he says that he was just 'seeing how near he could get' to that wire fence, and that there was no lack of judgement.

When this type of pilot gets a cable break and nearly stalls or spins in, he will claim that he was under finite control of the glider, and so on. Few instructors, if any, are convinced by such charades, and even supposing they were the pilot concerned is his own worst enemy as one day he will make the sort of mistake that no amount of talking will solve, for he won't be around to talk at all.

There is also the pilot who is lacking in confidence, and the instructor will have to build this confidence up for him, but not so much that he becomes over-confident and causes other problems. Added to this, there is the erratic pilot, who is sometimes very, very good and sometimes very, very bad, and this type of pilot can make the keenest instructor scratch his head.

So you can see that the lot of the instructor is one of long hours, hard work, sometimes little satisfaction and often little thanks. As I once read:

*I've flogged you and I've flayed you,  
By the living God that made you,  
You're a better man than I am Gunga Dhin.*

## GLIDER PILOT

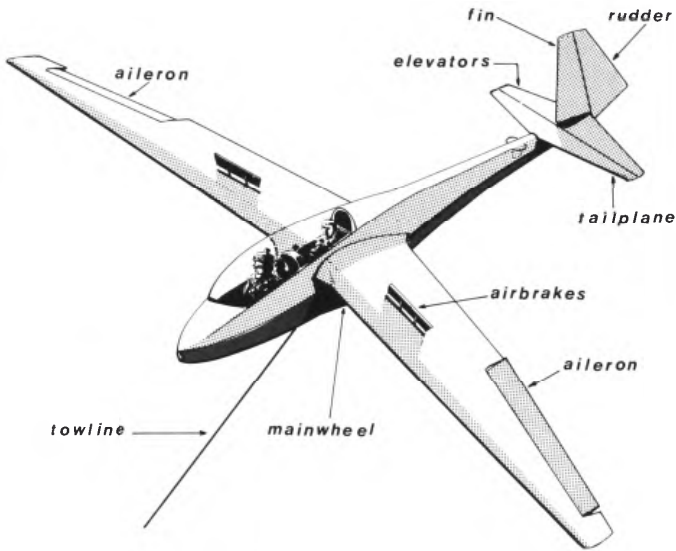

**2 SEAT K-13**

I make no apology to any other glider pilot when, on their behalf, and particularly on my own behalf, I say to the gliding instructors, I thank you, gentlemen.

---

## Postscript

---

This is only a sketch of glider aerodynamics to enable the reader to follow the book. For those interested in further reading, I suggest: *Theory of Flight for Glider Pilots*, by R. C. Stafford Allen, published by Oliver & Boyd, London.

**Why do wings fly?** To allow the condition of flight to take place air must flow over the wings of an aircraft. With a glider the weight of the machine provides the motive force and enables this to happen.

If you were to saw through a wing at right angles and look at the section, end on, you would see the profile of the wing, sometimes referred to as the wing section or *aerofoil*. The aerofoil is similarly shaped to a 'tear-drop', and is designed so that the air reaching its nose separates into two channels. One channel goes over the top of the aerofoil and the other underneath, both meeting at the trailing edge and returning into one airflow. The channel of air following the upper side of the aerofoil has to follow a longer course than its counterpart, and in order to reach the trailing edge at the same time must accelerate and thin out. This reduces the pressure on top of the aerofoil and therefore the wing, while the air beneath the wing increases in pressure. This difference in pressure gives 'lift' and allows the wing to gain height, or fly.

**What is the function of the fuselage and tailplane?** The fuselage provides room for the pilot and a means of stabilising the wing by

# GLIDER PILOT

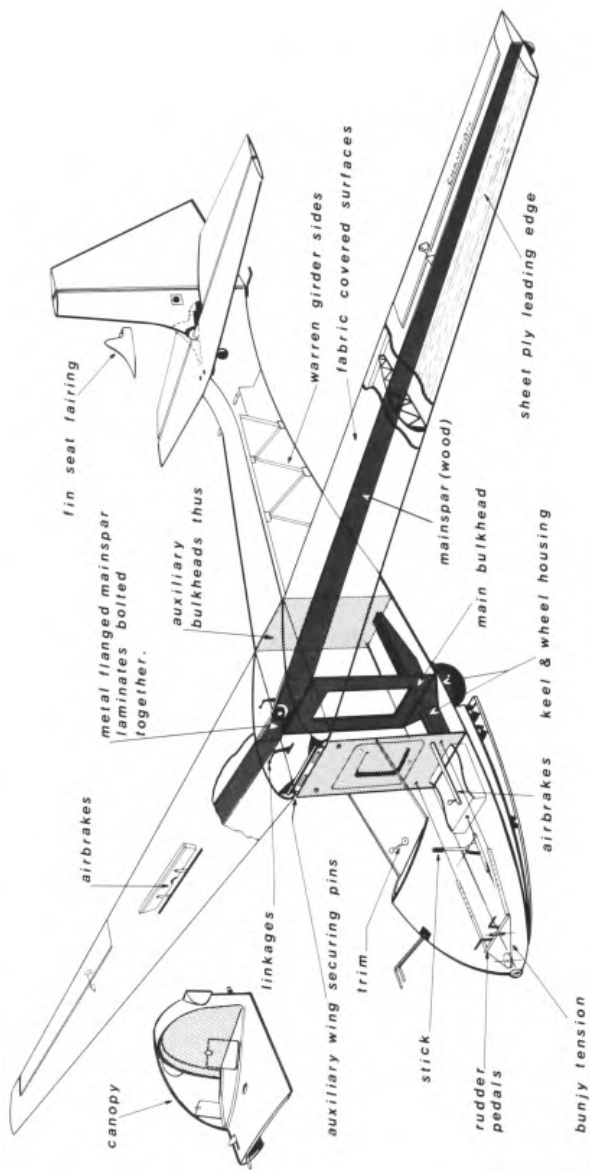

STRENGTH LINK OF MAINSPAR, MAIN BULKHEAD, KEEL & WHEEL HOUSING.

placing a tail at the other end. The tail is inclined at a lower degree to the airflow than the wing, thereby stabilising the wing. The amount of this stability depends upon the distance of the tail from the wings and the area of the tail compared with that of the wings.

**What is the fin and what is the rudder?** The fin, of a certain area and distance from the balance point of the glider, serves to keep it on a straight course and damp out any swinging from side to side of the nose. The rudder is really part of the fin but is hinged onto it to allow the pilot (through the use of the rudder pedals) to turn it left or right in order to swing the nose left or right. It does not primarily *turn* the glider.

**What are ailerons?** These are two hinged surfaces like the rudder only attached one to each wing, and when one goes down and assists to lift this wing, the other goes up and assists in lowering that wing. They are coupled to the control stick, and when the stick is pushed to the left the left wing will go down, and when pushed to the right the right wing will go down. They perform their function by the pressure of the airflow going over them, in much the same way as a wing itself, and are always operative when making turns in a glider.

**What are the elevators?** They too are hinged surfaces, in this instance part of the tailplane. They are also coupled to the stick, which when eased back pulls the elevators up into the airflow. The airflow then pushes the tail down and the nose up; by easing the stick forward the opposite is accomplished.

**What is a trim tab?** A small oblong surface, this time hinged to the elevators and operated by a separate *trim lever*. It is used to assist the pilot in keeping the elevators at an angle selected initially by the stick. It also uses the pressure of the airflow to hold that angle constant, as for cruising flight, to relieve the loads on the stick and for landing approaches where the increased speed may be held constant. An aircraft trimmed for cruising, at, say, 40 knots, will fly at that speed and attitude even when the pilot takes his hands from the stick and such a condition is said to be *trimmed out*.

**What is the centre of gravity?** It is the point in the aircraft where



it will balance in equilibrium in all directions if suspended from that point. For all intents and purposes it is referred to generally as a position relating to the width (chord) of the wing, in which it is a percentage of this width. If the centre of gravity is  $33\frac{1}{3}$  per cent this refers to the balance point of the whole aircraft being at a point one third back from the leading edge of the wing. This is why the weight of the pilot is important as the centre of gravity must be kept within certain limits if the aircraft is to remain safe to fly.

**Through what axes does a glider rotate and with which controls?**

- 1 *The yawing axis* This swings the nose from side to side and is controlled by the rudder.
- 2 *The pitching axis* This pitches the nose up or down and is controlled by the stick in a backward or forward motion, transmitting the action to the elevators.
- 3 *The rolling axis* This rotates the aircraft through an imaginary line from the nose to the tail, and is again controlled by the stick. The stick in turn transmits its actions to the ailerons.

**How does a glider turn?** You turn the glider by applying stick movement to the left or right, depending on which way you want to turn and simultaneously pushing with one foot or the other against the rudder pedals. If you want to turn left, you will apply the stick to the left and press your left foot against the rudder pedals, turning and banking the aircraft to the left and at the same time easing back a little on the stick to keep the nose level and the speed constant. To come out of the turn you move the stick and pedals in the opposite direction, and as you straighten up centralise the controls again and check your speed.

**What is the angle of attack?** It is the angle at which the wing is attacked by the airflow. The higher the angle adopted (controlled by the stick and elevators) the more lift will result.

**What is the stall?** A wing will stall when the angle of attack goes beyond around 15 degrees and the airflow over the top surface breaks away and cannot reach and join up with the air travelling along the lower surface to the trailing edge. The wing then ceases to provide usable lift and the aircraft will, when this angle of attack

## POSTSCRIPT

is reached, drop its nose until a lower angle of attack is made and usable lift produced again. If the stalling angle is reached slowly the nose may not drop, but the aircraft will lose height very quickly.

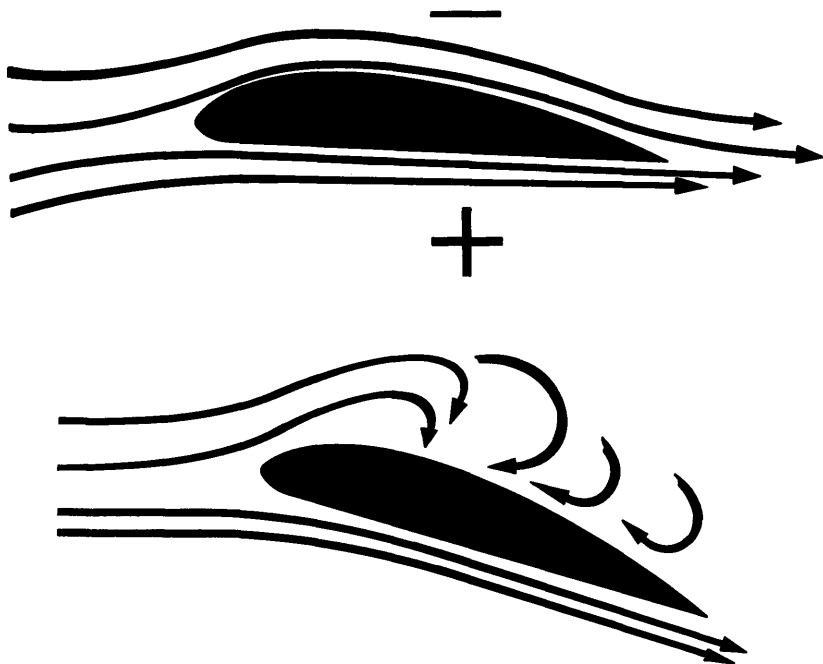

**What is the spin?** The spin is a yawed and stalled condition of flight that results if left uncorrected, in a stalled, yawed and spiralling descent.

**What is the spin recovery procedure?** Full opposite rudder . . . pause . . . stick progressively forward until the rotation stops . . . centralise the rudder and pull out from the resulting dive.

**What are pre-flight checks?** C.B., S.I.T., C.B. is a mnemonic (memory tag) consisting of the initials for the various checks.

*C Controls* Test for full movement and correct function.

*B Ballast* Cockpit weight allowances including pilot and parachute shown on cockpit placard in the cockpit itself.

*S Straps* Sound and secure.

- I Instruments* Checked and set where necessary.  
*T Trim* Test full and free movement. Set for forward of neutral for take-off.  
*C Canopy* Sound and locked for take-off.  
*B Brakes* (or spoilers) Check operation and retract and lock prior to take off.

**What are pre-landing checks? U.S.T.A.L.**

- U Undercarriage* Down and locked if retractable.  
*S Speed* Increased slightly for approach.  
*T Trim* Re-trim to new speed.  
*A Airbrakes* Hand on airbrakes ready for use.  
*L Lookout* A good lookout for other aircraft in the circuit.

**What are the stalling, cruising and landing speeds of some gliders?** As an example, we consider the Slingsby 'Swallow'. The cruising speed will vary for pilots of different weights, but take 40 knots as average. The stalling speed will be below 30 knots giving a 10-knot range before stalling in level flight, while approach speeds are determined as being a minimum of 10 knots added to the cruising speed. In this instance it would make 50 knots, plus as much as a further 10 knots when conditions such as high winds and gradients demand it. This would make the approach speed in the case of the 'Swallow' in these circumstances 60 knots plus, although without turbulence and gradients in high winds 55 knots would suffice.

**What is a weak link?** A link in the towing cable that will break when an excess of 1,000 lbs. strain is put upon it. It is inserted in order to safeguard the structure of the glider, so that the weak link always breaks before the wings.

**Are glider pilots restricted by laws?** Yes, detailed in *Air Law for Glider Pilots*, published by the British Gliding Association, London.

**What is the cost of joining a gliding club?** About £20, initially, and thereafter around £15 per annum depending on the club. Flying (winch launching) fees run from 40 p per launch up to and including ten minutes, and thereafter on a *pro-rata* basis, at roughly £1.50 per hour.

## POSTSCRIPT

**What is the minimum age for a solo pilot?** Sixteen years of age on or before the day of the first solo.

**What is the maximum age for a glider pilot?** None, providing you are reasonably fit.

**Is gliding dangerous?** Would you believe: 'No'? It is as dangerous as you care to make it. The instruction is designed to make you a safe and thoughtful pilot, and it is largely up to you how dangerous or safe you become.

**Are there proficiency exams in gliding?** Yes. 'A' and 'B' certificates on passing solo standard and then 'C', Bronze 'C', Silver 'C', Gold 'C' and Diamonds, all for *duration, gains in height and distance*, plus written papers on aerodynamics, air law, meteorology and field landings, etc.

**Do I have to go in for competitions?** No, not unless you wish to, and are competent to do so.

**Do I have to buy a glider?** Not unless you choose to. The flying costs mentioned already cover the cost of using club machines and instruction.

**Who controls the safety of gliders structurally?** The instructors control the daily inspections to ensure that each glider is airworthy, and every year the gliders go away to an approved inspector for a Certificate of Airworthiness, when a thorough inspection is carried out before a certificate is issued for the following year.

**What is the controlling body for gliding in the U.K.?** The British Gliding Association, Artillery Mansions, Artillery Row, London, S.W.1.

**Is there a bi-monthly journal covering the sport?** Yes. *Sailplane and Gliding*, published by the same body as the B.G.A., at the address given above.

**Could I become a glider pilot?** Yes, because at the worst you'll do better than I did at the beginning.

GLIDER PILOT

**Is there anything I can do to help gliding?** Yes. Loan this book to your friend.

# Further Reading for "Air" Enthusiasts

## MAN POWERED FLIGHT

Primarily aimed at the student of man-powered flight, Dr. K. Sherwin of the University of Liverpool analyses the problems of design structure and operation, adding his own theories for production of a practical "pedal scooter". Over 128 specially selected illustrations convey a pictorial history of progress and combined with more than 90 text diagrams, form a scientific reference work of great value to all students of aviation. O 85344 046 8

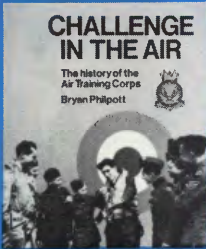

## CHALLENGE IN THE AIR

The story of the Air Training Corps from its tenuous beginnings after the 1914-18 war when the idea of a youth organisation with an aeronautical flavour formed in the minds of two young ex-servicemen—to its present position as the main source of recruits for the Royal Air Force. The story unfolds via the formation of the Air League's Air Defence Cadet

Corps, through the difficult days of World War 2—during which the Air Training Corps was formed—to the present day. O 85242 213 X

---

**MODEL AND ALLIED PUBLICATIONS LIMITED**  
13/35 Bridge Street, Hemel Hempstead, Herts, England

---